

KDI 1903TCR-MP KDI 2504TCR-MP

OWNER MANUAL



 **LOMBARDINI**
BY KOHLER. MARINE

REGISTRATION OF MODIFICATIONS TO THE DOCUMENT

Any modifications to this document must be registered by the drafting body, by completing the following table.

Released by	Document code	Model N°	Edition	Revision	Issue date	Review date	Edited by	Endorsed
Technical Documentation	ED0053032450	51567	5	5	03/2018	05/2021	Technical Documentation	

Translated from the original manual in Italian language.

Data reported in this issue can be modified at any time by Lombardini Marine.



Important

- Connect to <http://iservice.lombardini.it> and download the latest version of this manual onto your device.

NOTE: you can select the desired language before downloading the manual, as shown in the figure below.

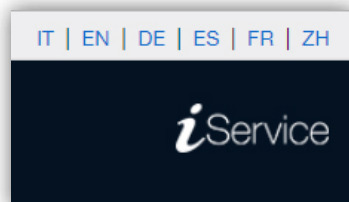

1 - GENERAL INFORMATION

1.1 Manual's purpose 6
 1.2 Glossary and Definitions 6
 1.3 Emission 6
 1.4 Service request 6
 1.5 Engine component identification 7
 1.6 Manufacturer and motor identification data 8

2 - TECHNICAL INFORMATION

2.1 General description of the engine 9
 2.2 Engine specifications 9
 2.3 Engine dimensions (mm) - with TMC 260 reversing gear ... 9
 2.4 Oil 10
 2.4.1 SAE oil classification 10
 2.5 Fuel 11
 2.5.1 Fuel for low temperatures 11
 2.5.2 Biodiesel fuel 11
 2.5.3 Synthetic fuels: GTL, CTL, BTL, HV 11
 2.5.4 Non-Road Fuels 12
 2.5.5 Emission-Related Installation Instructions 12
 2.6 Coolant recommendation 12
 2.7 Battery recommendation 12
 2.8 Control panel 13

3 - SAFETY INFORMATION

3.1 Safety information 14
 3.2 General remarks 14
 3.2.1 Note for OEM/installer 14
 3.2.2 Note for end user 14
 3.3 Safety signal description 16
 3.3.1 Adhesive safety plates 16
 3.3.2 Safety guards 16
 3.3.3 Warnings 16
 3.4 Information and safety signals 17
 3.5 Safety and environmental impact 17
 3.6 Location of safety labels on engine 18

4 - INFORMATION ABOUT USE

4.1 Pre-start check 19
 4.2 Break-in running 19
 4.3 Starting and turning off 19
 4.3.1 Starting 19
 4.3.2 After starting 19
 4.3.3 Turning off 19
 4.4 Refuelling 20
 4.5 Engine oil filling 20
 4.6 Reversing gear oil top-up 21
 4.7 Coolant filling 22

5 - INFORMATION ABOUT MAINTENANCE

5.1 Useful information about maintenance 23
 5.2 Periodic maintenance 23
 5.3 Oil level check 24
 5.4 Rubber hoses check 25
 5.5 Check coolant level 26
 5.6 Zinc anode, intercooler and radiator check 26
 5.7 Check and setting alternator standard belt tension 31
 5.8 Control water filter cartridge fuel 31
 5.9 Product preservation 32
 5.10 Engine storage (up to 6 months) 32
 5.11 Engine storage (over 6 months) 32
 5.12 Engine starting after storage 32
 5.13 Unused machine 33
 5.13.1 Operations for the engine 33

6 - INFORMATION ABOUT REPLACEMENTS

6.1 Engine oil replacement 34
 6.2 Oil filter cartridge replacement 35
 6.3 Fuel filter cartridge replacement 36
 6.4 Water pump impeller replacement 36
 6.5 Alternator belt replacement 37
 6.6 Coolant replacement 38
 6.7 Air cleaner replacement 38
 6.8 Disposal and scrapping 38

7 - INFORMATION ABOUT FAILURES

<i>7.1 Useful information about failures.....</i>	<i>39</i>
<i>7.2 Error signals on the control panel.....</i>	<i>40</i>

8 - APPLICATION AND VALIDATION PROCESS

<i>8.1 Application and Validation process for marine engine... </i>	<i>41</i>
<i>8.2 Prescriptions to be respected.....</i>	<i>42</i>

9 - INFORMATION ABOUT WARRANTY

<i>Warranty terms.....</i>	<i>45</i>
----------------------------	-----------

10 - GLOSSARY

<i>Glossary</i>	<i>48</i>
<i>Symbols and units of measurement</i>	<i>50</i>

1.1 Manual's purpose

- This manual contains the instructions needed to carry out proper use and maintenance of the engine, therefore it must always be available, for future reference when required.
- This manual is an integral part of the engine, in the event of transfer or sale, it must be attached to it.
- Safety pictograms can be found on the engine and it is the operator's responsibility to keep them in a perfectly visible place and replace them when they are no longer legible.
- Information, description and pictures in this manual reflect the state of the art at the time of the marketing of engine.
- However, development on the engines is continuous. Therefore, the information within this manual is subject to change without notice and without obligation.
- **Kohler Engines** reserves the right to make, at any time, changes in the engines for technical or commercial reasons.
- These changes do not require **Kohler Engines** to intervene on the marketed production up to that time and not to consider this manual as inappropriate.
- Any additional section that **Kohler EnginesR** will deem necessary to supply some time after the main text shall be kept together with the manual and considered as an integral part of it.
- The information contained within this manual is the sole property of **Kohler Engines**. As such, no reproduction or replication in whole or part is allowed without the express written permission of **Kohler Engines**.

1.2 Glossary and Definitions

The paragraphs, tables and figure are divided into chapter with their progressive numbers.

Ex: Par. 2.3 - chapter 2 paragraph 3.

Tab. 3.4 - chapter 3 table 4.

Fig. 5.5 - chapter 5 figure 5.

The references of the objects described in the text and in figure and number are indicated by letters, which are always and only related to the paragraph you are reading unless there are specific references to other figures or paragraphs.

The figure are based on model 2504 TCR-MP, where necessary the version 1903 TCR-MP is illustrated.

NOTE: *All data, measurements and relevant symbols are shown in the glossary section.*

1.3 Emission

The power of propulsion engines for marine use is measured in compliance with Directive 2013/53/EU.

1.4 Service request

- The complete and updated list of authorized Kohler Co. service centers can be found on websites: www.kohlerengines.com & www.lombardinigroup.it/dealer-locator.
- If you have any questions regarding your warranty rights and responsibilities or the location of the nearest Kohler Co. authorized service location, you should contact Kohler Co. at 1-800-544-2444 or access our website at www.kohlerengines.com (USA and North American).

1.5 Engine component identification

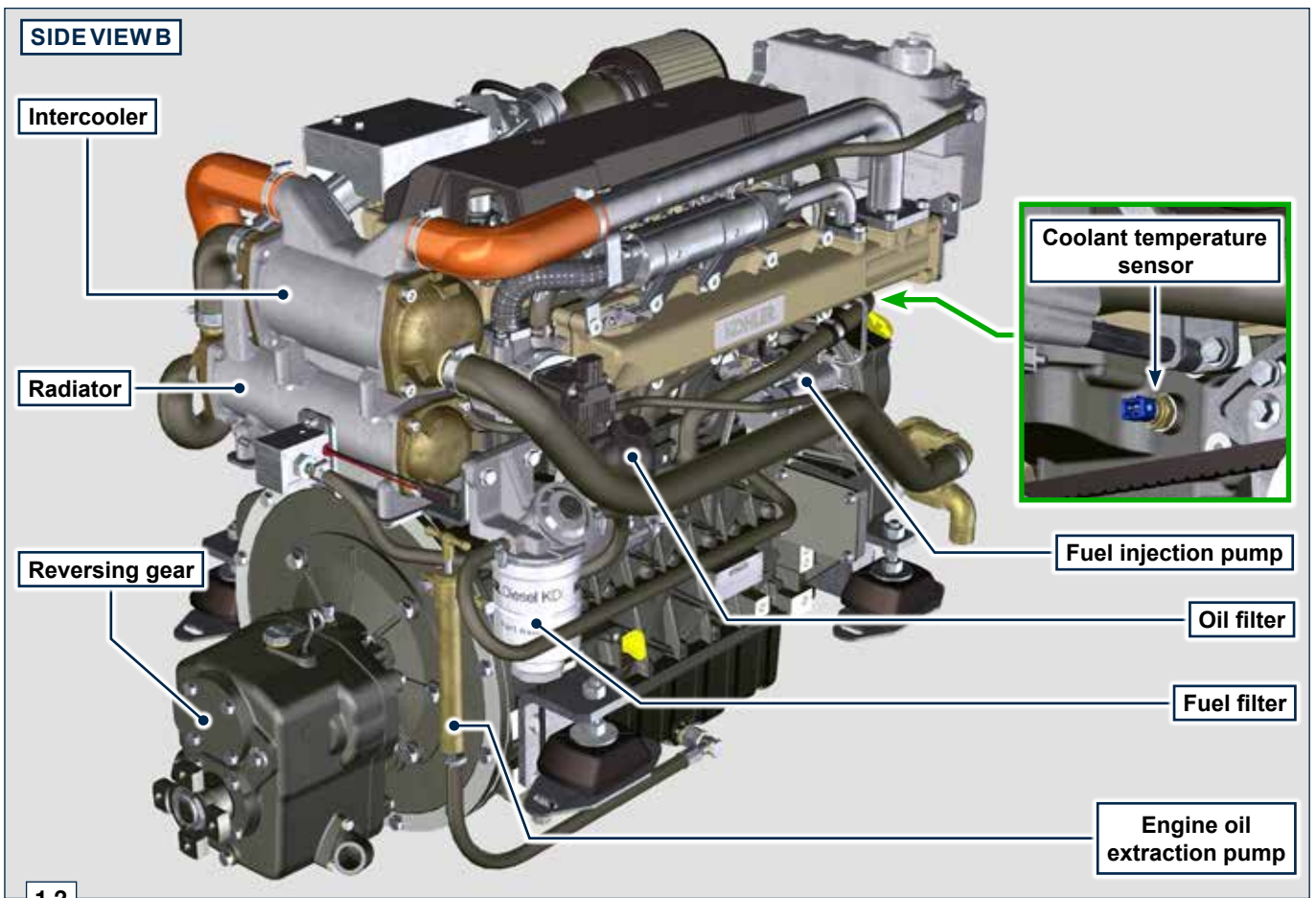
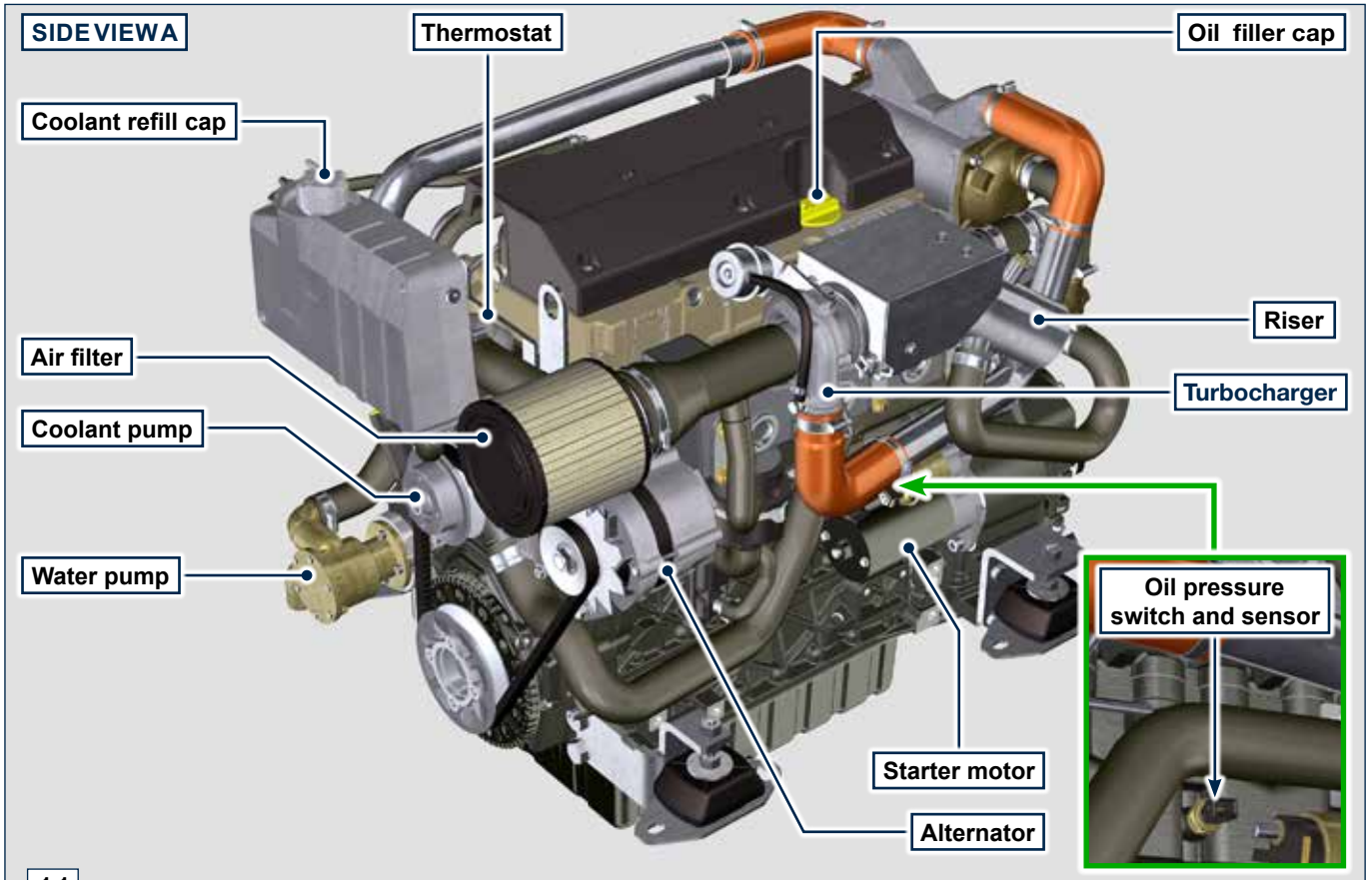

1.6 Manufacturer and motor identification data

The engine identification nameplate is located on side A or B as below.

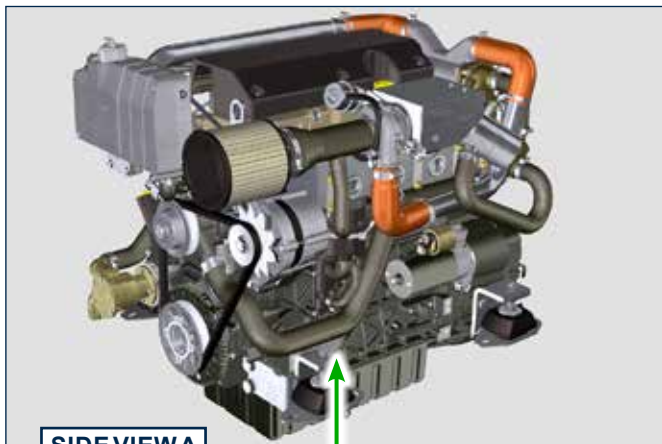

SIDE VIEW A



SIDE VIEW B

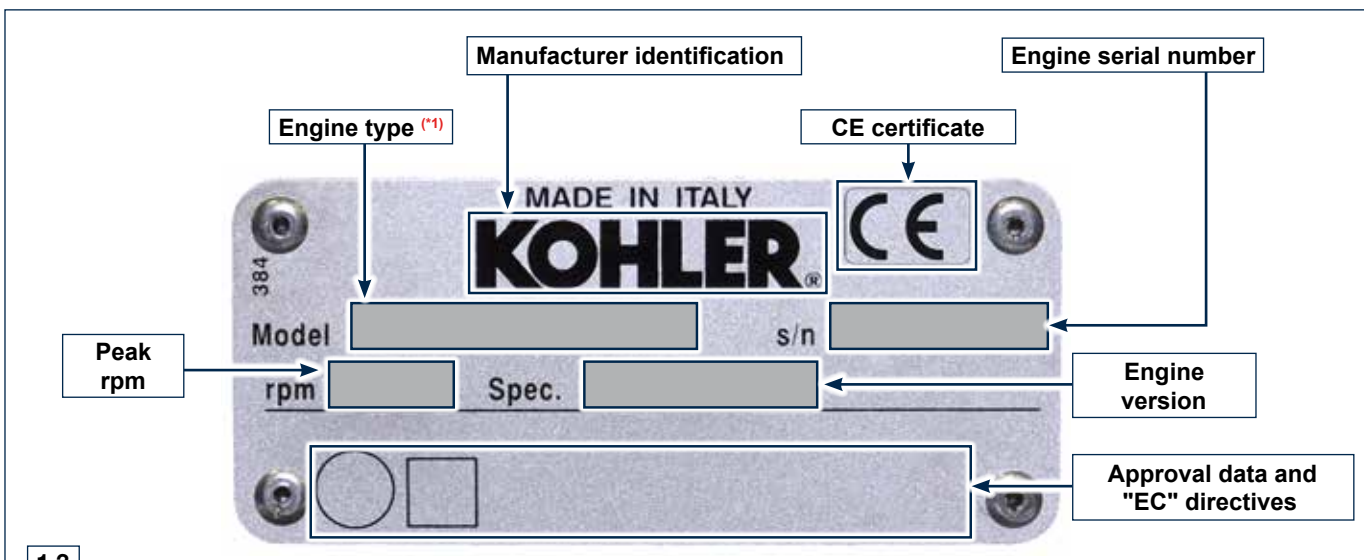

1.3

(*):

the engine model reported on the name plate in Fig. 1.3 is generic. For a specific model, refer to the engine model shown on the name plate situated on the rocker arm cover, as shown in Fig. 1.4.



1.4

2.1 General description of the engine

- 4-stroke, in-line cylinders Diesel engine;
- Liquid-cooling system;
- 4 valves per cylinder with hydraulic tappets;
- Turbocharger with Waste-gate valve;
- Direct injection.

2.2 Engine specifications

2.1

TECHNICAL DATA		UNIT OF MEASURE	KDI 1903 TCR-MP	KDI 2504 TCR-MP
ENGINE TYPE				
CYLINDERS		n.	3	4
BORE		mm	88	88
STROKE		mm	102	102
DISPLACEMENT		cm ³	1861	2482
MAX INCLINATION DURING OPERATION (EVEN IN COMBINED)	TRANSVERSAL	α	35° MAX	35° MAX
	LONGITUDINAL	α	15° MAX	15° MAX
OIL CAPACITY (MAX LEVEL.) INCLUDING OIL FILTER	STANDARD VERSION	lt.	8.9	11.5
DRY WEIGHT		kg	277	300

2.3 Engine dimensions (mm) - with TMC 260 reversing gear

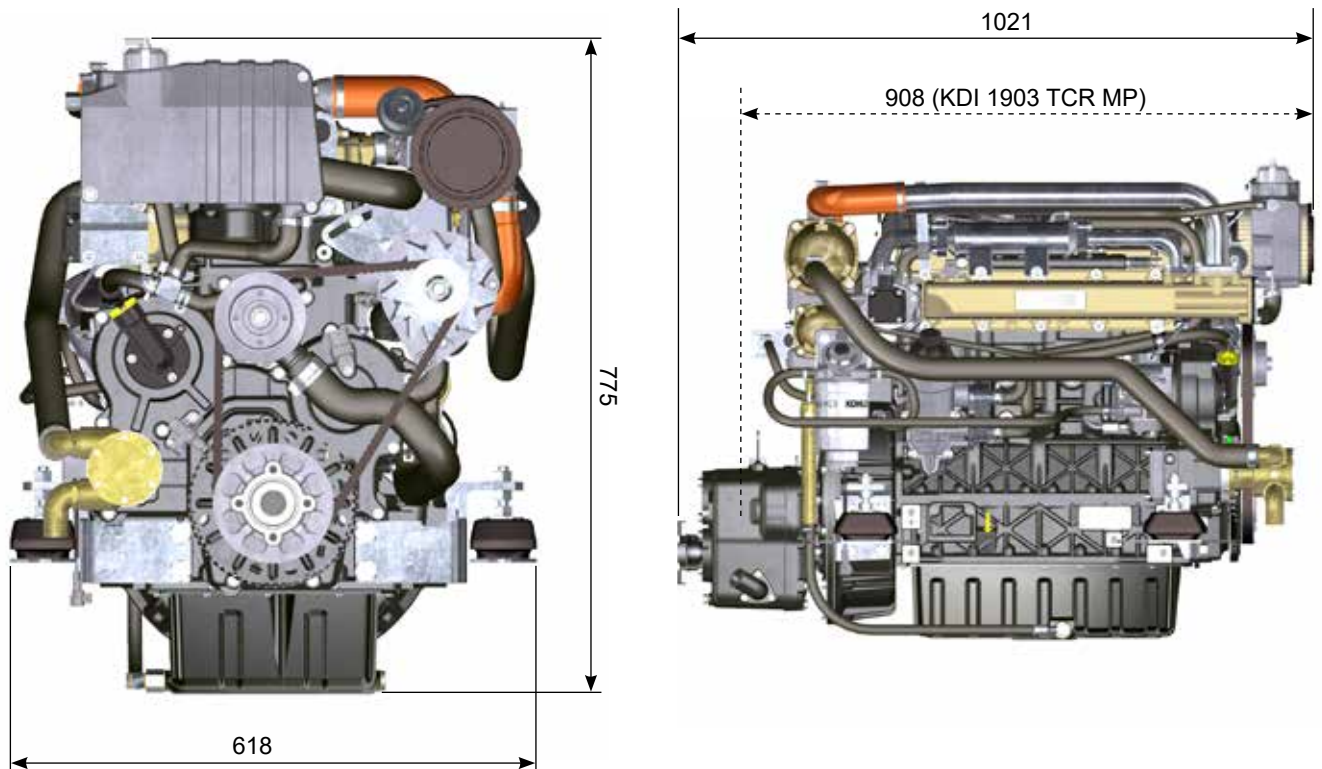

2.4 Oil



Important

- The engine may be damaged if operated with improper oil level.
- Do not exceed the MAX level because a sudden increase in engine rpm could be caused by its combustion.
- Use only the recommended oil to ensure adequate protection, efficiency and service life of the engine.
- The use of lubricants other than recommended may shorten the engine life.
- Viscosity must be appropriate to the ambient temperature to which the engine is to be exposed (**Par. 2.4.1**).

2.4.1 SAE oil classification

- In the SAE classification, oils are identified according to viscosity without considering any other qualitative characteristic.



Danger

- Prolonged skin contact with the exhausted engine oil can cause cancer of the skin.
- If contact with oil cannot be avoided, thoroughly wash your hands with soap and water as soon as possible.
- For the exhausted oil disposal, refer to [Par. 6.8 DISPOSAL and SCRAPPING](#).

- The code is made up of two numbers. The first number refers to the viscosity when cold, for use during winter ("W"= winter), while the second number is for viscosity at high temperatures.

2.2

RECOMMENDED OIL

VISCOSITY	SAE	15W-40 (-15°C ÷ +50°C) 10W-30 (-25°C ÷ +40°C) 10W-40 (-25°C ÷ +50°C) 5W-30 (-30°C ÷ +40°C) 0W-40 (-40°C ÷ +50°C)
	API	CI-4 Plus CI-4 CH-4
WITH SPECIFICATIONS	ACEA	E7 E5

- Filtration of oils is critical to proper operation and lubrication; always change filters regularly as specified in this manual.

2.4.2 Reversing gear oil

NOTE: Refer to the technical documentation of the reversing gear supplied with the engine.

2.5 Fuel



Important

- Use of other types of fuel could damage the engine. Do not use dirty diesel fuel or mixtures of diesel fuel and water since this will cause serious engine faults.
- Any failures resulting from the use of fuels other than recommended will not be warranted.



Warning

- Clean fuel prevents the fuel injectors from clogging. Immediately clean up any spillage during refuelling.
- Never store diesel fuel in galvanized containers (i.e. coated with zinc). Diesel fuel and the galvanized coating react chemically to each other, producing flaking that quickly clogs filters or causes fuel pump and/or injector failure.

2.3

FUEL COMPATIBILITY

EN 590 (biodiesel content max. 7% (V/V))
ASTM D 975 Grade 1-D S15
ASTM D 975 Grade 2-D S15
NATO F-54, equivalent to diesel fuel in accordance with EN 590
EN 590 or ASTM D 975 Grade 1, 2 -D S15 Arctic Diesel
JIS K 2204 No. 1, No. 2

NOTE: *In a warranty case the customer must prove by a certificate from the fuel supplier that an allowed fuel was used.*

Those engines are designed for fuels in accordance with EN 590 and ASTM D975 for a cetane number of at least 45. Since those engines are not equipped with exhaust gas after-treatment, they can be operated with diesel fuels with sulfur content up to 500 mg/kg (ppm). Compliance with the emission requirements is guaranteed only with sulfur content up to 350 mg/kg (ppm). Fuels with a sulfur content > 50 mg/kg demand a shorter lubricating oil change interval. This is set at 250hrs. However, the engine oil must be changed when the Total Base Number TBN is reduced to 6.0 mgKOH/g test method ASTM D4739. Do not use low SAPS engine oils.

2.5.1 Fuel for low temperatures

- When operating the engine in ambient temperatures lower than 0 degrees C, use suitable low temperature fuel normally available from fuel distributors and corresponding to the specifications of [Tab. 2.3](#).
- These fuels reduce the formation of paraffin in diesel at low temperatures.
- When paraffin forms in the diesel, the fuel filter becomes blocked interrupting the flow of fuel.

2.5.2 Biodiesel fuel

- Fuels containing 10% methyl ester or B10, are suitable for use in this engine provided that they meet the specifications listed in the [Tab. 2.3](#).
- DO NOT USE vegetable oil as a biofuel for this engine.

2.4

BIODIESEL COMPATIBILITY

Biodiesel according to EN 14214 (only permissible for mixture with diesel fuel at max. 10% (V/V))
US biodiesel according to ASTM D6751 – 09a (B100) (only permissible for mixtures with diesel fuel at 10% (V/V))

2.5.3 Synthetic fuels: GTL, CTL, BTL, HV

It is a well-known fact that engines which are operated for longer periods with conventional diesel fuel and then converted to synthetic fuels suffer shrinkage of polymer seals in the injection system and thus fuel leaks. The reason for this behavior is that the aromatic-free synthetic fuels can lead to a change in the swelling behavior of polymer seals.

Therefore, conversion from diesel fuel to synthetic fuel may only be done after changing the critical seals. The problem of shrinkage does not occur when an engine was operated with synthetic fuel from the start.

2.5.4 **Non-Road Fuels**

Other non-road fuels may be used if they comply with all the limit values of EN 590 except for the fuel density, the cetane number and the sulfur content.

The following limits apply for these parameters:

2.5	FUEL PARAMETER	UNIT	LIMIT VALUE
	Cetane number		Min. 49
	Fuel density at 15°C	Kg/m ³	820 - 860
	Sulfur content	mg/kg or ppm	max. 500

2.5.5 **Emission-Related Installation Instructions**

Failing to follow the instructions in the applications guidebook when installing a certified engine in a piece of nonroad equipment violates federal law (40 CFR 1068.105(b)), subject to fines or other penalties as described in the Clean Air Act.

OEM must apply a separate label with the following statement: "ULTRA LOW SULFUR FUEL ONLY" near the fuel inlet.

Ensure you are installing an engine appropriately certified for your application. Constant speed engines may only be installed on constant speed equipment for constant speed operation.

If you install the engine in a way that makes the engine's emission control information label hard to read during normal engine maintenance, you must place a duplicate label on the equipment, as described in 40 CFR 1068.105.

2.6 Coolant recommendation

A mixture of 50% demineralized water and 50% low silicate ethylene glycol based coolant liquid must be used.

Use a Long Life or Extended Life Heavy Duty OAT coolant free of: silicates, phosphates, borates, nitrites and amines.

The following ethylene-glycol based engine coolant for all models within KDI engine family may be used:

- OAT (Organic Acid Technology) Low Silicate: **ASTM D-3306 D-6210**
- HOAT (Hybrid Organic Acid Technology) Low Silicate: **ASTM D-3306 D-6210**

The above coolants in concentrated formulation must be mixed with distilled, deionized, or demineralized water. A pre-mixed formulation (40-60% or 50-50%) can be used directly when available.



Important

- Do not mix ethylene glycol and propylene glycol based coolants. Do not mix OAT and HOAT based coolant. OAT performance life can be drastically reduced if contaminated with nitrite-containing coolants.
- Never use automotive-type coolants. These coolants do not contain the correct additives to protect heavy – duty diesel engines.

OAT coolants are maintenance free up to 6 years or 6000hrs of operation , provided that the cooling system is topped up using the same type of coolant. Do not mix different coolant types. Test the coolant condition annually with coolant test strips.

HOAT are not all maintenance free and it is recommended to have SCA (Supplemental Coolant Additives) added at the first maintenance interval

2.7 Batteries recommendation

Batteries not supplied by Kohler Engines.

2.6	RECOMMENDED BATTERIES	
	AMBIENT TEMPERATURE	BATTERY TYPE
	> - 15°C	12V 100 AH - 800 CCA/SAE
	-15°C ÷ -25°C	12V 110 AH - 950 CCA/SAE
	< - 25°C	12V 120 AH - 1000 CCA/SAE

2.8 Control panel

Tab. 2.7 shows the control panel components.

2.7

POS.	DESCRIPTION
A	Panel ignition switch with key switch
B	Engine on push button
C	Engine rpm indicator
D	Engine data or errors display
E	Engine data or errors push button
F	Maintenance errors reset push button
G	Engine off push button

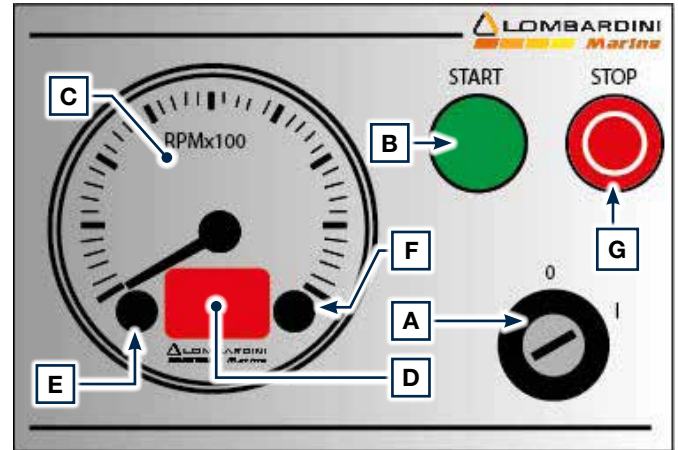

Tab. 2.8 shows data that can be consulted on display D by pressing push button E.

2.8

POS.	DESCRIPTION
Coolant °C 20	Coolant temperature (°C)
Oil bar 0.0	Oil pressure (bar)
Battery V 12.7	Battery voltage (V)
Cons l/h 0.7	Consumption per hour
FAULT CODE 105 3 1 / 2	Fault code

POS.	DESCRIPTION
Hour h 1 1	Total and partial hours of operation (h) - To reset partial hours, simultaneously press push buttons E and F for 3 seconds
Service h 001 300	Hours left for maintenance (h)
Dimmer Control ■■■■■■■■■■	Backlighting adjustment - Press push button E for 3 seconds - Press push button E to decrease brightness or F to increase it
Turbo bar 0.95	Turbocharger pressure

3.1 Safety information

- The intended use of the engine is in conformity with the machine on which it is mounted.
- Any use of the machine other than that described cannot be considered as complying with its intended purpose as specified by KOHLER .
- KOHLER declines all responsibility for any change to the engine not described in this manual made by unauthorized KOHLER personnel.
- A proper use of the engine, a strict observance of the rules listed below and the rigorous application of all these precautions will avoid the risk of accidents or injuries.
- Those who carry out the use and maintenance on the engine must wear the safety equipment and the accident-prevention guards.
- KOHLER declines all direct and indirect liability for failure to comply with the standards of conduct contained in this manual.
- KOHLER cannot consider every reasonably unforeseeable misuse that may cause a potential danger.

3.2 General remarks

3.2.1 Note for OEM

- When installing the KDI engines, always bear in mind that any variation to the functional systems may result in serious failures to the engine.
- Any improvement must be verified at KOHLER testing laboratories before application of the engine.
- In case the approval to a modification is not granted, KOHLER shall not be deemed responsible for any consequential failures or damages to the engine.
- The engine may only be assembled on a machine by personnel specifically trained by KOHLER and who work in compliance with the existing documentation.
- The engine has been built to the specifications of a machine manufacturer, and it is his responsibility to ensure that all necessary action is taken to meet the essential and legally prescribed health and safety requirements. Any use of the machine other than that described cannot be considered as complying with its intended purpose as specified by KOHLER, which therefore declines all responsibility for accidents caused by such operations.

3.2.2 Note for end user

- The following indications are dedicated to the user of the machine in order to reduce or eliminate risks concerning engine operation and the relative routine maintenance work.
- The user must read these instructions carefully. Failure to do this could lead to serious danger for his personal safety and health and that of any persons who may be in the vicinity of the machine.
- On starting, make sure that the engine is as horizontal as possible, unless the machine specifications differ.
- Make sure that the machine is stable to prevent the risk of overturning.
- The engine must not operate in places containing inflammable materials, in explosive atmospheres, where there is dust that can easily catch fire unless specific, adequate and clearly indicated precautions have been taken and have been certified for the machine.
- To prevent fire hazards, always keep the machine at least one meter from buildings or from other machinery.
- Children and animals must be kept at a due distance from operating machines in order to prevent hazards deriving from their operation.
- Thoroughly wash and clean all the external parts of the engine before performing any operation, in order to avoid the accidental introduction of impurities/foreign bodies. Use only water and/or appropriate products to clean the engine. If cleaning engine with a pressure washer or steam cleaner, it is important to maintain a minimum distance of at least 200mm between the surface to be washed and the nozzle.
- Avoid directing the nozzle on electrical components, cable connections and sealed rings (oil seals etc). Thoroughly wash and clean the area surrounding the engine following the instructions provided by machine manufacturer.
- Fuel and oil are inflammable. The tank must only be filled when the engine is off. Before starting, dry any spilt fuel.
- Make sure that no soundproofing panels and the ground or floor on which the machine is standing have not soaked up any fuel.
- Fuel vapour is highly toxic. Only refuel outdoors or in a well ventilated place.
- Do not smoke or use open flames when refuelling.
- During operation, the surface of the engine can become dangerously hot. Avoid touching the exhaust system in particular.
- Before proceeding with any operation on the engine, stop it and allow it to cool.
- Always open the radiator plug or expansion chamber with the utmost caution, wearing protective garments and goggles.
- The coolant fluid is under pressure. Never carry out any inspections until the engine has cooled.

- If there is an electric fan, do not approach the engine when it is still hot as the fan could also start operating when the engine is at a standstill.



Important

- The oil must be drained whilst the engine is hot. Particular care is required to prevent burns. Do not allow oil to come into contact with the skin because of the health hazards involved. It is recommended to use an oil intake pump.
 - During operations that involve access to moving parts of the engine and/or removal of rotating guards, disconnect and insulate the negative wire (-) of the battery to prevent accidental short-circuits and to stop the starter motor from being energized.
 - Check belt tension only when the engine is off.
 - Fully tighten the tank cap each time after refuelling. Do not fill the tank right to the top but leave an adequate space for the fuel to expand.
 - To start the engine follow the specific instructions provided in the engine and/or machine operating manual. Do not use auxiliary starting devices not originally installed on the machine (e.g. Startpilot).
 - Before starting, remove any tools that were used to service the engine and/or machine. Make sure that all guards have been refitted.
- Do not mix fuel with elements such as oil or kerosene. Failure to comply with this prohibition will cause the non-operation of the catalyst and non-observance of the emissions declared by KOHLER.
 - Pay attention to the temperature of the oil filter when the filter itself is replaced.
 - Only check, top up and change the coolant fluid when the engine is off and reached the ambient temperature. Coolant fluid is polluting, it must therefore be disposed of in the correct way.
 - Do not use air and water jets at high pressures on cables, connectors and injectors.



Important

- Only use the eyebolts **A** installed by KOHLER to move the engine (Fig. 3.1).
- The angle between each lifting chain and the eyebolts shall not exceed 15° inwards.
- The correct tightening of the lifting screws is 25Nm.
- Do not interpose spacers or washers between the eyebolts and engine head.
- Provided that the above requirements are met, if the lifting eyebolts are subject to permanent deformation (inwards), all subsequent lifting operations must be performed in order to prevent them from bending in the opposite direction.

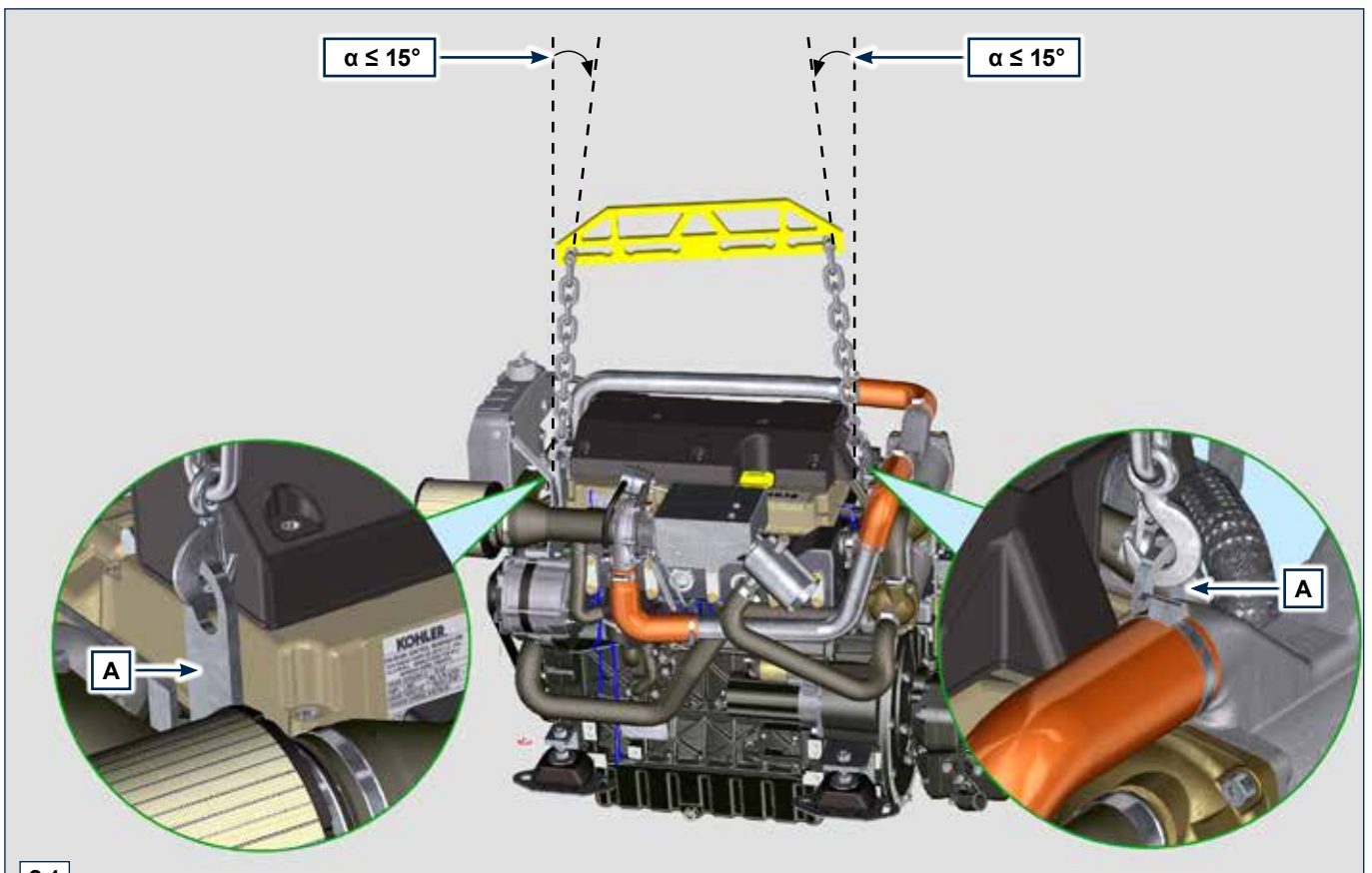

3.1

3.3 Safety signal description

- To ensure safe operation please read the following statements and understand their meaning.
- Also refer to your equipment manufacturer's manual for other important safety information.
- This manual contains safety precautions which are explained below.
- Please read them carefully.

3.3.1 Adhesive safety plates

The following is a list of the adhesive safety plates that may be found on the engine, which indicate potential points of danger to the operator ([Par. 3.6](#)).



Read the Operation and Maintenance handbook before performing any operation on the engine.



Hot Parts.
Danger of burns.



Presence of rotating parts.
Danger of jamming or cutting.



Presence of explosive fuel.
Danger of fire or explosion.



Presence of steam and pressurized coolant.
Danger of burns.



Lifting point.



Electrical shock.
Danger of severe scalding or death.



High pressure fluid.
Danger of fluid penetration.



Lethal Exhaust Gases.
Danger of poisoning or death.

3.3.2 Safety guards

Hereunder is a list of safety guards that must be worn prior to carrying out any type of operation and to avoid potential harm to the operator.



Use protective gloves before carrying out the operation.



Use protective glasses before carrying out the operation.



Use sound absorbing protections before carrying out the operation.

3.3.3 Warnings

Hereunder is a list of safety warnings that may be found in the manual, which advise you to pay attention when carrying out particular procedures that may be potentially dangerous to the operator or things.



Danger

- This indicates situations of grave danger which, if ignored, may seriously threaten the health and safety of individuals.



Important





- This indicates particularly important technical information that should not be ignored.







Warning



- This indicates that failure to comply with it can cause minor damage or injury.

3.4 Information and safety signals

ACCIDENTAL START	
	Accidental Starts can cause severe injury or death.
<p><i>Before working on the engine or equipment, disconnect the battery negative (-) wire.</i></p>	
HOT PARTS	
	Hot Parts can cause severe burns.
<p><i>Engine components can get extremely hot from operation. Do not touch engine while operating or just after stopping. Never operate the engine with heat shields or guards removed.</i></p>	
ROTATING PARTS	
	Rotating Parts can cause severe injury.
<p><i>Stay away while engine is in operation. Keep hands, feet, hair, and clothing away from all moving parts to prevent injury. Never operate the engine with covers, shrouds, or guards removed.</i></p>	
LETHAL EXHAUST GASES	
	Carbon Monoxide can cause severe nausea, fainting or death.
<p><i>Avoid inhaling exhaust fumes and never run the engine in a closed building or confined area. Carbon monoxide is toxic, odorless, colorless, and can cause death if inhaled.</i></p>	
ELECTRICAL SHOCK	
	Electrical Shock can cause injury.
<p><i>Do not touch wires while engine is running.</i></p>	

	HIGH PRESSURE FLUID RISK OF PUNCTURE
	High Pressure Fluids can puncture skin and cause severe injury or death.
<p><i>Do not work on fuel system without proper training or safety equipment. Fluid puncture injuries are highly toxic and hazardous. If an injury occurs, seek immediate medical attention.</i></p>	

	EXPLOSIVE FUEL
	Explosive fuel can cause fires and severe burns.
<p><i>Fuel is flammable and its vapours can ignite. Store fuel only in approved containers, in well ventilated, unoccupied buildings. Do not fill the fuel tank while the engine is hot or running, since spilled fuel could ignite if it comes in contact with hot parts or sparks from ignition. Do not start the engine near spilled fuel. Never use fuel as a cleaning agent.</i></p>	

	EXPLOSIVE GAS
	Explosive Gas can cause fires and severe acid burns.
<p><i>Charge battery only in a well ventilated area. Keep sparks, open flames, and other sources of ignition away from the battery at all times. Batteries produce explosive hydrogen gas while being charged. Keep batteries out of the reach of children. Remove all jewelry when servicing batteries. Before disconnecting the negative (-) ground cable, make sure all switches are OFF. If ON, a spark will occur at the ground cable terminal which could cause an explosion.</i></p>	

CALIFORNIA PROPOSITION 65 WARNING
<p><i>Diesel engine exhaust and some of its constituents are known to the State of California to cause cancer, birth defects, and other reproductive harm.</i></p>

3.5 Safety and environmental impact

Every organisation has a duty to implement procedures to identify, assess and monitor the influence of its own activities (products, services, etc.) on the environment. Procedures for identifying the extent of the impact on the environment must consider the following factors:

- Liquid waste.
- Waste management.
- Soil contamination.
- Atmospheric emission.
- Use of raw materials and natural resources.
- Regulations and directives regarding environmental impact.

In order to minimise the impact on the environment, **KOHLER** now provides a number of indications to be followed by all persons handling the engine, for any reason, during its expected lifetime.

- All components and fluids must be disposed of in accordance with the laws of the country in which disposal is taking place.
- Keep the fuel and engine control systems and the exhaust pipes in efficient working order to limit environmental and noise pollution.
- When discontinuing use of the engine, select all components according to their chemical characteristics and dispose of them separately.

3.6 Location of safety labels on engine

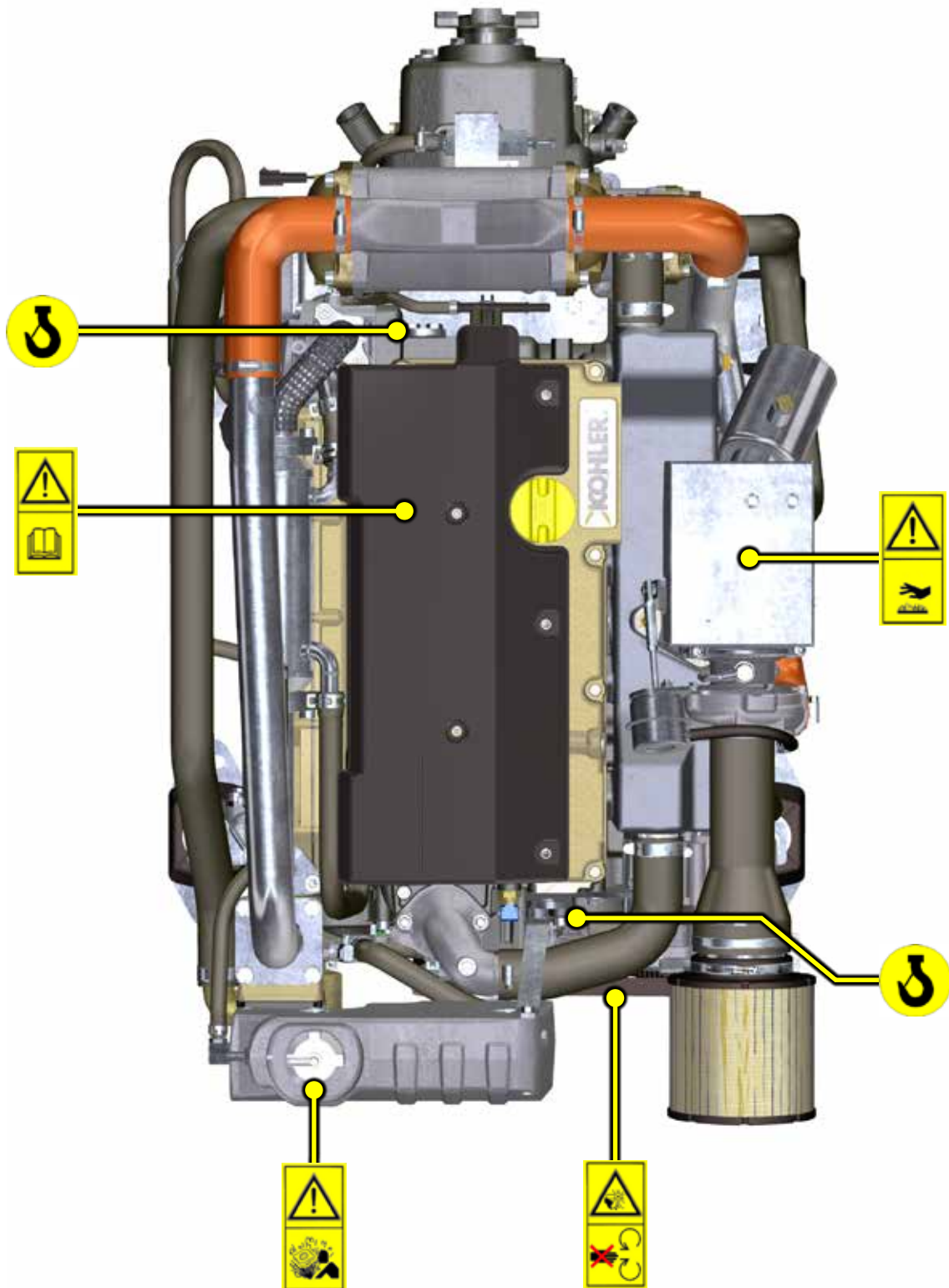

4.1 Pre-start check

- Read carefully the following pages and carry out the operations described below in accordance with the instructions specified.



Important

- Non compliance with the operations described in the following pages involves the risk of damages to the engine and vehicle on which it is installed as well as personal and/or property damage.
- Increase the frequency of maintenance operations in heavy working conditions (engine starts but stops, very dusty and hot environments, etc...).

4.2 Break-in running

NOTE: For the first 50 hours of engine operation, it is advisable not to exceed 75% of the maximum power supplied.

4.3 Starting and turning off

4.3.1 Starting

1. Check the level of the engine oil, fuel and coolant and fill if necessary ([Par. 4.5](#) and [Par. 4.6](#)).
2. Put the ignition key in the ignition switch.
3. Turn the key to 1 position.
4. Press the Start push button for it to start automatically.



Important

- At the first fuelling or if the tank was empty filling the fuel system ([Par. 6.3](#) point 7).
- RPM reading delay is normal.
- If engine does not start after two attempts see [Tab. 7.1](#) and [Tab. 7.2](#) to found the cause.

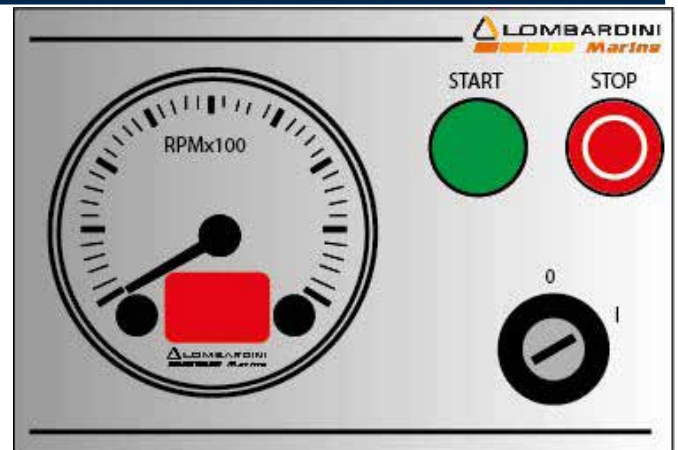

4.3.2 After starting



Warning

- Make sure that all the warning lights on the control panel are off when the engine is running.
 - Check for any leakages from the pipes on first start-up
1. Run at minimum speed for a few minutes according to table.

4.9

AMBIENT TEMPERATURE	TIME
≤ -20°C	2 minutes
from -20° C to -10°C	1 minutes
from -10° C to -5° C	30 seconds
from -5° C to 5° C	20 seconds
≥ 5° C	15 seconds

4.3.3 Turning off

1. Do not turn off the engine with a full load or when it is running at the maximum rotation speed. Leave it running at idle speed without a load for approximately 1 minute.
2. Press the Stop push button (the engine turns off) and turn the key to position 0.

4.4 Refuelling



Important

- Before proceeding with operation, read [Par. 3.2.2.](#)



Danger

- Fill the engine off.
- The only approved fuels are those listed in [Tab. 2.3.](#)
- In those countries where diesel has a high sulphur content, it is advisable to lubricate the engine with a high alkaline oil or alternatively to replace the lubricating oil recommended by Kohler Engines more frequently.
- To avoid explosions or fire outbreaks, do not smoke or use open flames during the operations.
- Fuel vapours are highly toxic. Only carry out the operations outdoors or in a well ventilated place.
- Keep your face well away from the fuel fill to prevent harmful vapours from being inhaled.
- Dispose of fuel in the correct way and do not litter as it is highly polluting.
- When refuelling, it is advisable to use a funnel to prevent fuel from spilling out. The fuel should also be filtered to prevent dust or dirt from entering the tank.

Do not overfill the fuel tank. Leave room for the fuel to expand.

4.5 Engine oil filling



Important

- For safety precautions see [Par. 2.4.](#)
- Before proceeding with operation, read [Par. 3.2.2.](#)
- Place engine on horizontal surface to ensure accurate measurement of filling.

1. Loosen the oil filler cap A or the oil filler cap C if the cap A is not accessible.
2. Add the type oil recommended ([Tab. 2.1](#) and [Tab. 2.2](#)).

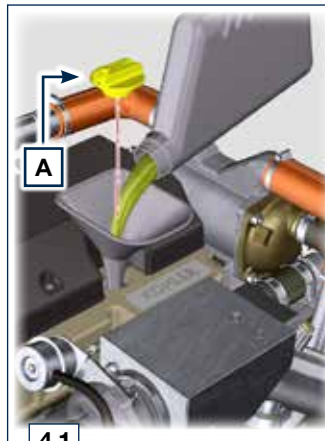

3. Remove the oil dipstick B and check that the level is up to but does not exceed the MAX.
4. If level is not at the MAX. level, add additional oil.
5. Re-tighten the cap A or C.



Important

- Do not exceed the MAX level on the dipstick.
- Do not use the engine with the oil level below the MIN.

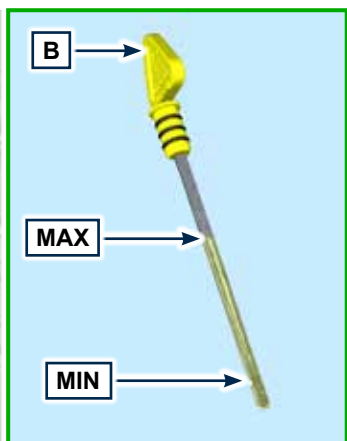
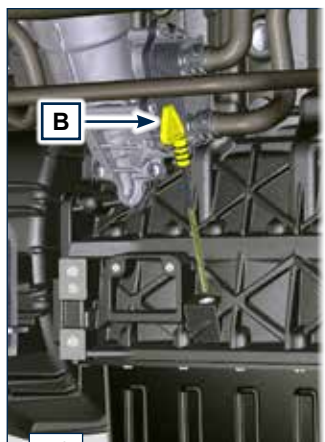

4.6 Reversing gear oil top-up



Important

- For safety precautions see [Par. 2.4](#).

- Before proceeding with operation, read [Par. 3.2.2](#).
- Place engine on horizontal surface to ensure accurate measurement of filling.

1. Loosen the oil filler cap A.
2. Add the type oil recommended ([Tab. 2.1](#) and [Tab. 2.4](#)).

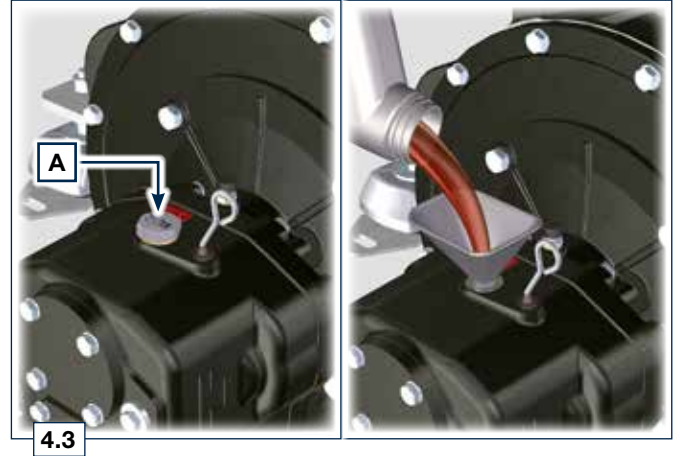

3. Remove the oil dipstick B and check that the level is up to but does not exceed the MAX.
4. If level is not at the MAX level, add additional oil and reinsert the dipstick correctly in the reversing gear seat C.
5. Re-tighten the cap A.



Important

- Do not exceed the MAX level on the dipstick.
- Do not use the engine with the oil level below the MIN.

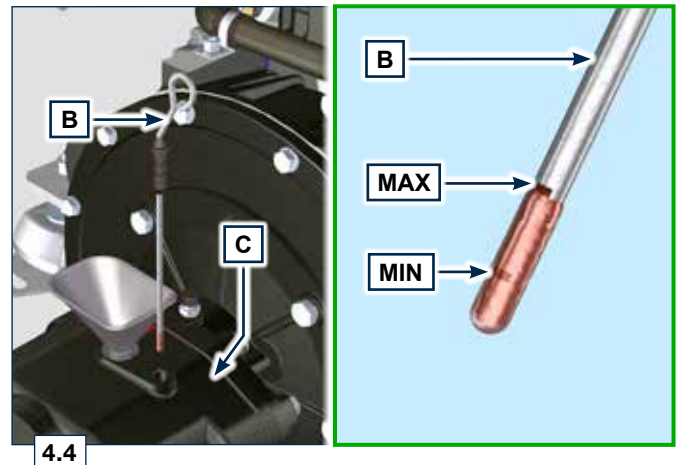

4.7 Coolant filling



Important

- Before proceeding with operation, read [Par. 3.2.2.](#)
- Place engine on horizontal surface to ensure accurate measurement of filling.



Warning

- An anti-freeze protection liquid (ANTIFREEZE) - mixed with decalcified water - must be used.
- The freezing point of the refrigerant mixture depends on the amount concentration in water.
- As well as lowering the freezing point, the antifreeze also raises the boiling point.
- A 50% mixture is recommended to ensure a general level at protection prevents the formation of rust, galvanic currents and calcium deposits.

NOTE: *Before proceeding with any operation on the engine, stop it and allow it to cool.*



Warning

- Presence of steam pressurized coolant danger of burns.
1. Loosen the cap A and fill the cooled exhaust manifold B with coolant composed of: 50% ANTIFREEZE and 50% decalcified water.
 2. Loosen the screw C release any air and tighten the screw C (Tightening torque of 8 Nm - Fig. 4.7).

NOTE: *The MAX filling level of the tank B is indicated by the "LEVEL" mark.*

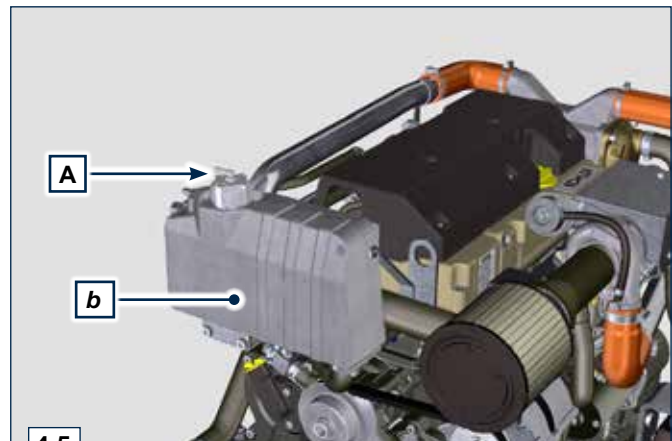

4.5

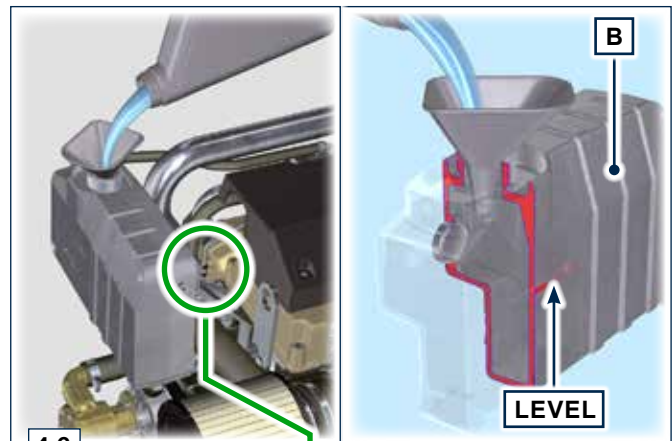

4.6

3. Re-tighten the cap A.
4. After a few minutes of operator, stop the engine and allow the liquid to cool returns to a ambient temperature and check the coolant level again.



4.7

5.1 Useful information about maintenance

- This chapter shows all operations described in the Tab. 5.1 and Tab. 5.2 that may be directly carried out by the user.
- Periodic inspection and maintenance operations must be carried out as indicated in this manual and are the responsibility of the user.
- Failure to comply with these service and maintenance intervals increases the risk of technical damage to the engine. Any non compliance makes the warranty become null and void.
- In order to prevent personal and property damage read carefully the instructions listed below before proceeding with any operation of the engine.



Warning

- Inspections must be made when the engine is off and cold.
- Place engine on level surface to ensure accurate measurement of oil level.
- Before starting, to avoid spillages of oil make sure that:
 - the oil dipstick is inserted correctly;
 - also check that:
 - oil drain plug and
 - oil filler cap are tightened firmly.



Important

- Before proceeding with operation, read [Par. 3.2.2.](#)

5.2 Periodic maintenance

The intervals of preventive maintenance in Tab. 5.1 and Tab. 5.2 refer to the engine operating under normal operating conditions with fuel and oil meeting the recommended specifications.

5.10

CLEANING AND CHECKING

OPERATION DESCRIPTION	PERIOD (HOURS)				PAR.
	100	250	500	5000	
Engine oil level ⁽⁸⁾					5.3
Coolant level ^{(8) (9)}					5.5
Zinc anode, intercooler and radiator surface ⁽²⁾					5.6
Standard alternator belt ⁽⁸⁾					5.7
Rubber hose (intake air / coolant)					5.4
Fuel hose					--
Starter Motor ⁽⁶⁾					--
Alternator ⁽⁶⁾					--

5.11

REPLACEMENT

OPERATION DESCRIPTION	PERIOD (HOURS)			PAR.
	250	500	5000	
Engine oil and oil filter cartridge ⁽¹⁾				6.1 / 6.2
Prefilter cartridge ⁽⁴⁾ and fuel filter ⁽¹⁾				6.3
Air filter ⁽²⁾				6.7
Water pump impeller ⁽¹⁾				6.4
Alternator belt ⁽³⁾				6.5
Intake manifold hose (air filter - intake manifold) ^{(6) (7)}				--
Coolant hoses ^{(6) (7)}				--
Fuel line hose ^{(6) (7)}				--
Coolant ^{(9) (11)}				6.6

1. In case of low use: 12 months.
2. The period of time that must elapse before checking depends on the environment in which the engine operates. The element must be cleaned and replaced more frequently under very dusty conditions.
2. In case of low use: 36 months.
3. Not supplied by **Kohler Engines**.
6. Contact **Kohler Engines** workshop.
7. The replacement interval is only an indication, it strongly depends from environmental condition and hose status detected during regular visual inspection.
8. The first check must be done after 10 hours.
9. Test the coolant condition annually with coolant test strips.
11. In case of low use: 24 months.

5.3 Oil level check



Important

- Place engine on horizontal surface to ensure accurate measurement of checking.
1. Loosen the oil filler cap A. Remove the oil dipstick B and check that the level is up to MAX.
 2. Pour in recommended oil until reaching the MAX level mark.
 3. Reinstall the oil dipstick B completely.
 4. Re-tighten the cap A and/or C.



Important

- Do not exceed the MAX level on the dipstick.
- Do not use the engine with the oil level below the MIN.

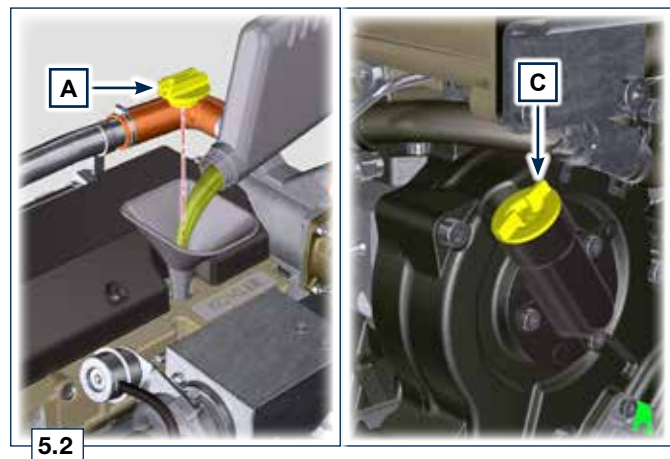
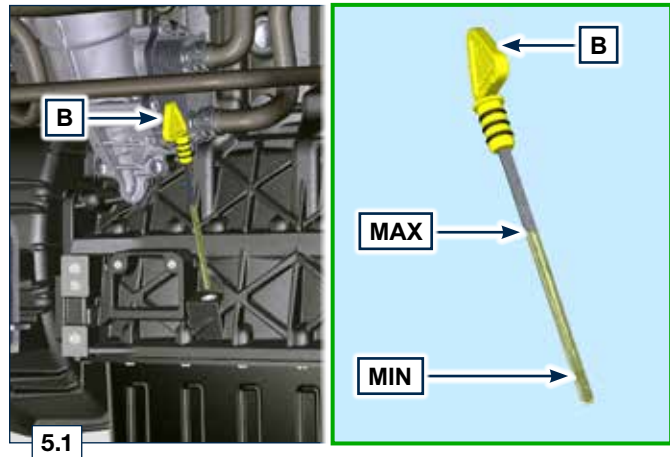



Danger

- For safety precautions see [Cap. 3](#).

5.4 Rubber hoses check

The check is carried out by exerting a slight deflection or bending along the pipe and near the hose clamps.

Components must be replaced if they have clear signs of cracks, tears, cuts, leaks and do not retain a certain degree of elasticity.



Important

- If hoses are damaged contact an authorized Kohler Engines workshop.

1. Check that the:

- Fuel system hoses A are intact.
- Hoses for the cooling circuit B1, B2.
- Manifolds for the air circuit C.
- Hoses for the oil circuit D.

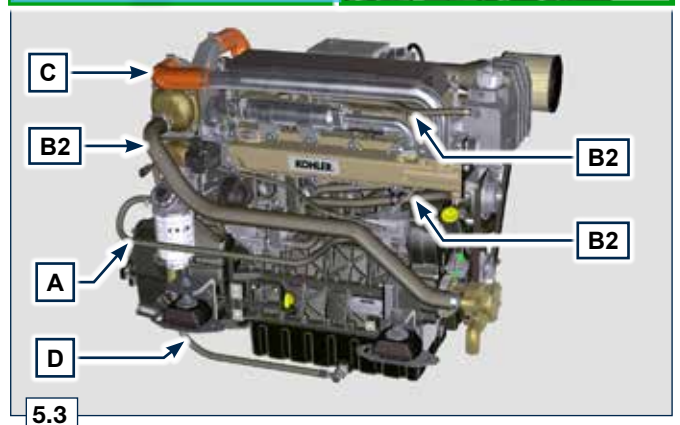
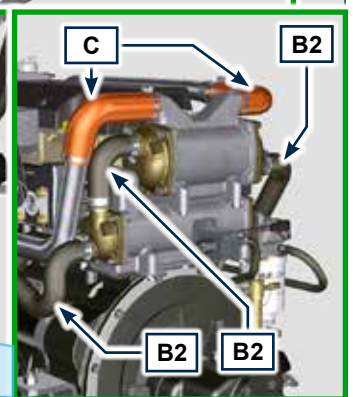
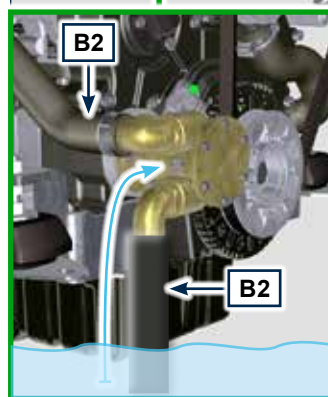
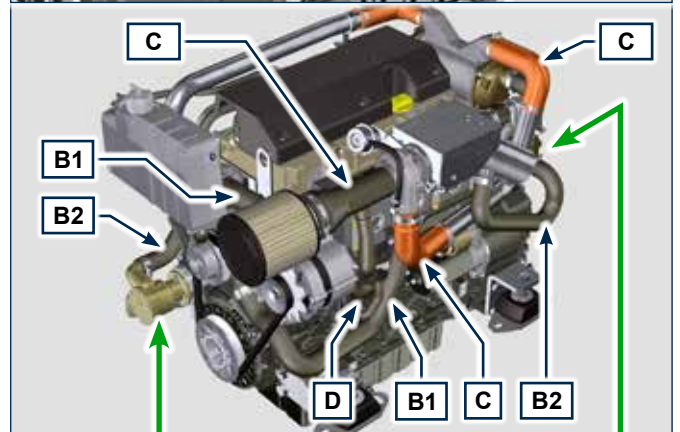
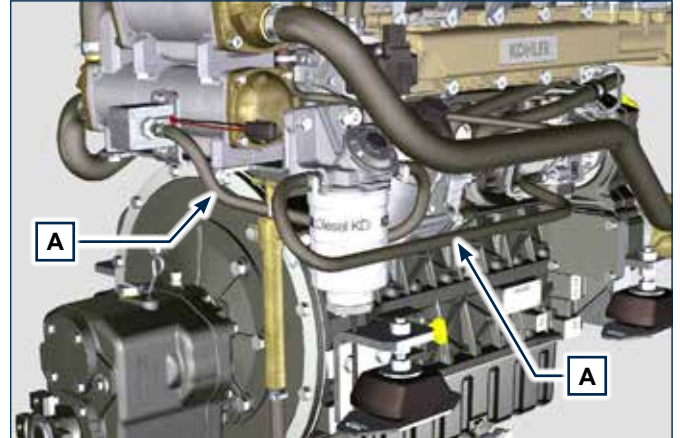

5.3

5.5 Check coolant level

NOTE: Before proceeding with any operation on the engine, stop it and allow it to cool.



Important

- Place engine on horizontal surface to ensure accurate measurement of checking.



Warning

- Presence of steam pressurized coolant danger of burns.

- Start the engine without the cap A on the tank B.
- Unscrew the screw C and fill the tank B until the coolant comes out from the screw C.

NOTE: The MAX filling level for the tank B is indicated by the "LEVEL" mark.

- Reinstall the cap A and capscrew C.

NOTE: For coolant filling see [Par. 4.6](#).



Warning

- Before starting make sure that the radiator cap and cap, if present, are installed correctly to avoid spillage of liquid or vapour at high temperatures.

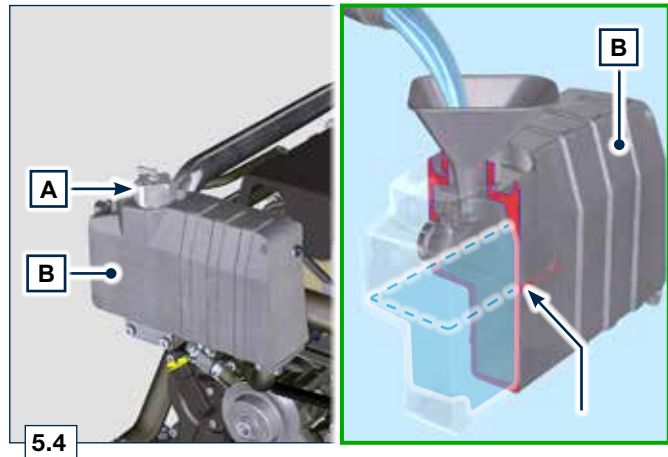

5.6 Zinc anode, intercooler and radiator check



Warning

- Protect the starter motor adequately against contact with liquids before starting operations.

- Unscrew the screw A from the raiser B.
- Replace the component A if the value C is lower than 8 mm.

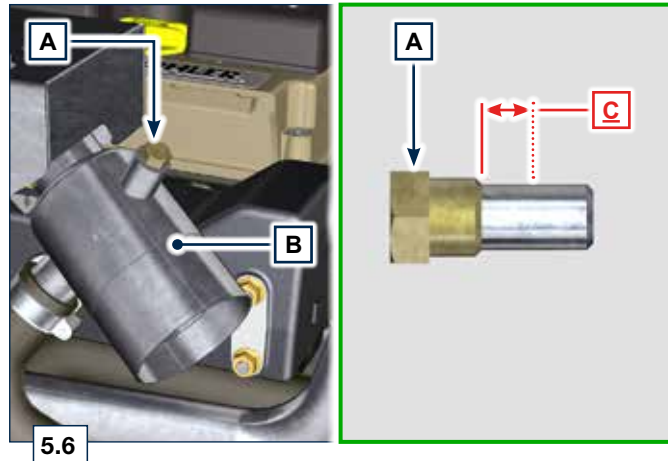

- Unscrew the cap D to drain all the liquid contained in the engine crankcase ducts into a suitable container and see [Par. 3.5](#).

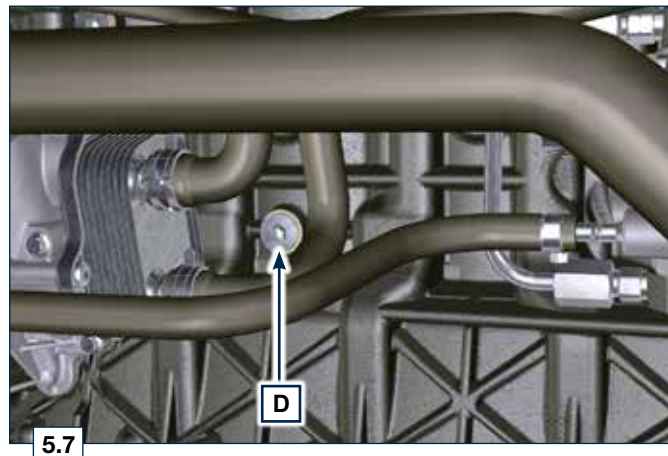

4. Loosen the clamps E of manifolds F and G.
5. Remove the manifolds from the components J and K.

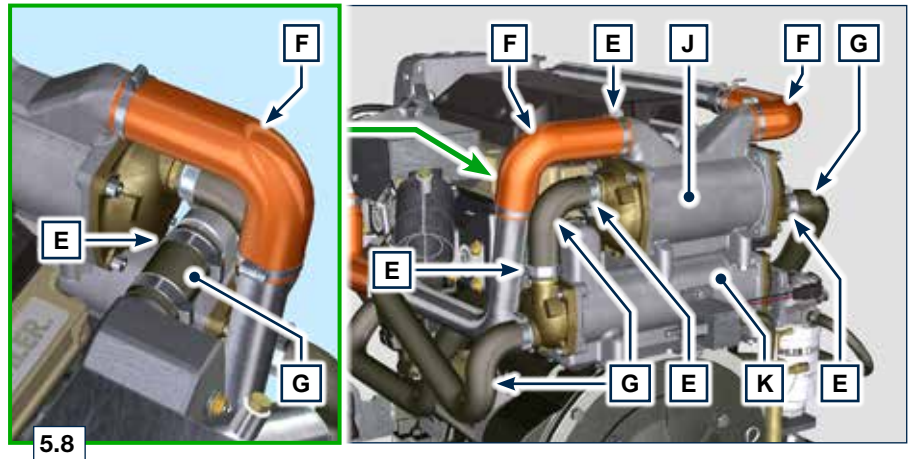

6. Unscrew the screws H, remove the unit J and K.

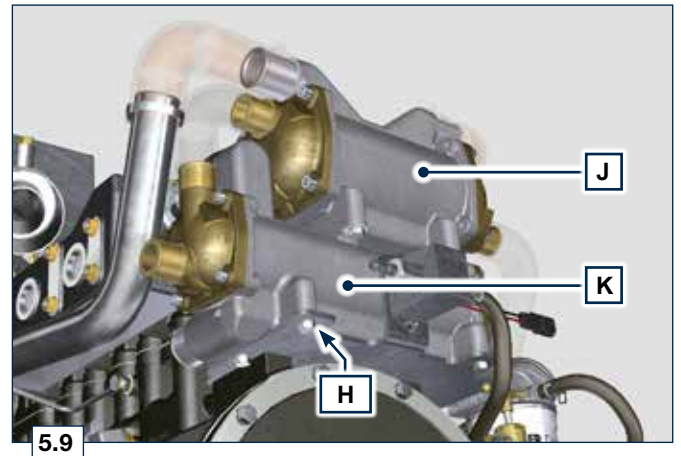

7. Unscrew the screws L, separate the components J and K.

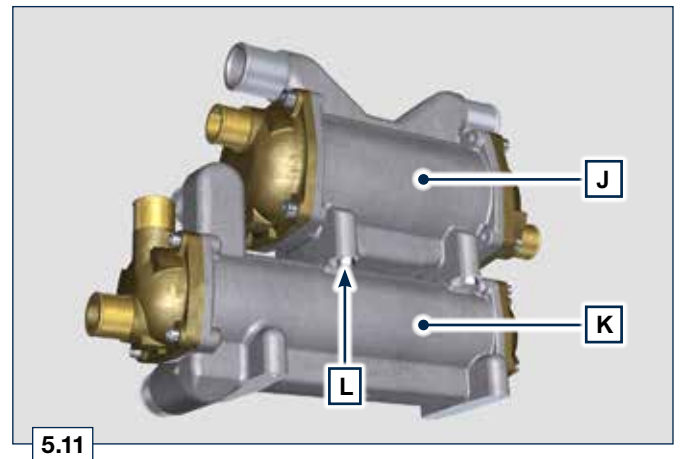

8. Unscrew the screws M, remove the cap N1, N2 and remove the radiator P from the support K.
9. Clean, immerse the components P, N1, N2 in a solution of distilled water with hydrochloric acid 10% at a temperature of 50°C.

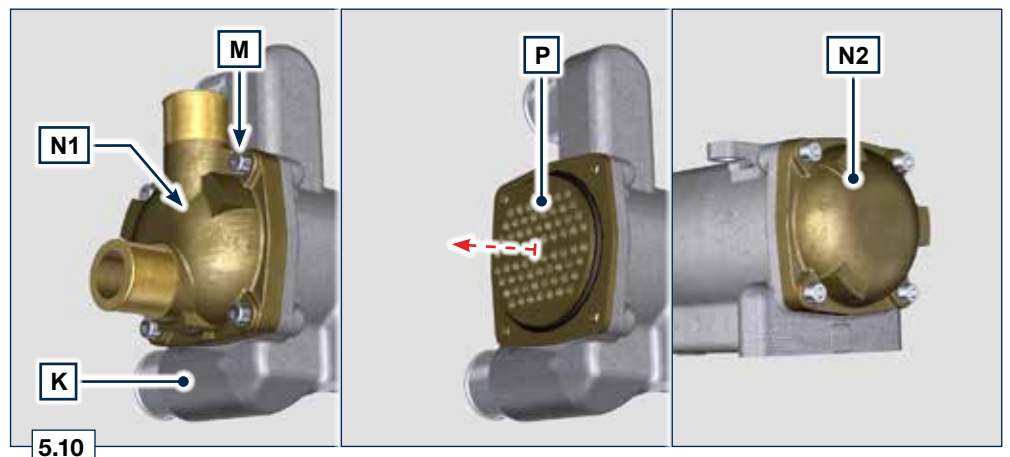

10. Check the radiator P for any kind of encrustations and dirt.
11. Check all the holes on the surfaces P1, P2 for any kind of encrustations and dirt.

NOTE: *if the inner side of the hoses on the surfaces P1 and P2 are encrusted even after carrying out the cleaning in point 9, clean the hoses with specific mechanical tools.*



Important

- Replace all the gaskets.

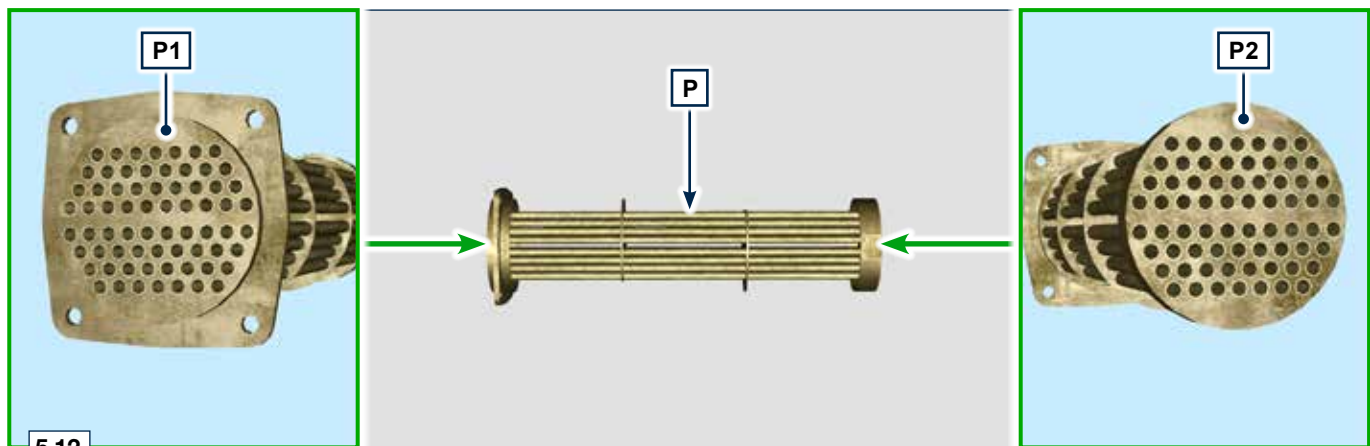

12. Insert the gasket Q2 on the radiator P.
13. Insert the radiator P into the support K until it stops.
14. Fix the cap N1 on the support K with the screws M interposing the gasket Q1 between N1 and P, the gasket Q3 between N2 and K. (tightening torque MIN 8 Nm, MAX 10 Nm)
15. Insert the gasket Q3 on the radiator P.
16. Fix the cap N2 on the support K with the screws M (tightening torque MIN 8 Nm, MAX 10 Nm).

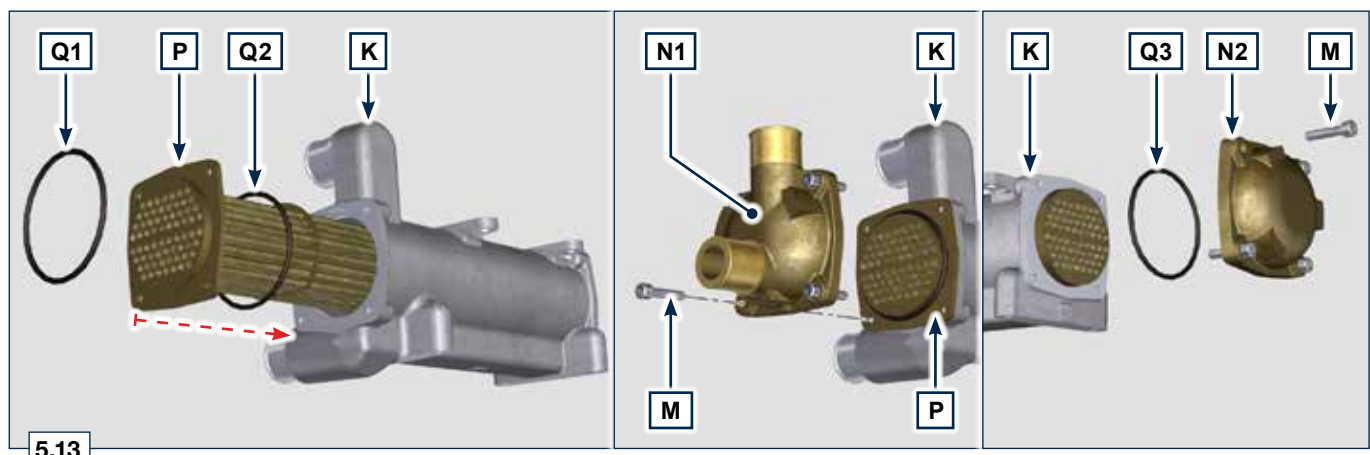

17. Connect a suitable pump on the unions R to clean the ducts with a solution of distilled water and hydrochloric acid 10%, at a temperature of 50° C.
18. At the end of the cleaning operations in point 3, rinse with water only the inner side of the ducts using the pump as described in point 17.
19. Unscrew the screws S, remove the cap T1, T2 and remove the intercooler U from the support V.
20. Clean, immerse the components T1, T2, U in a solution of distilled water with the addition of an alkaline soap compatible with aluminium.

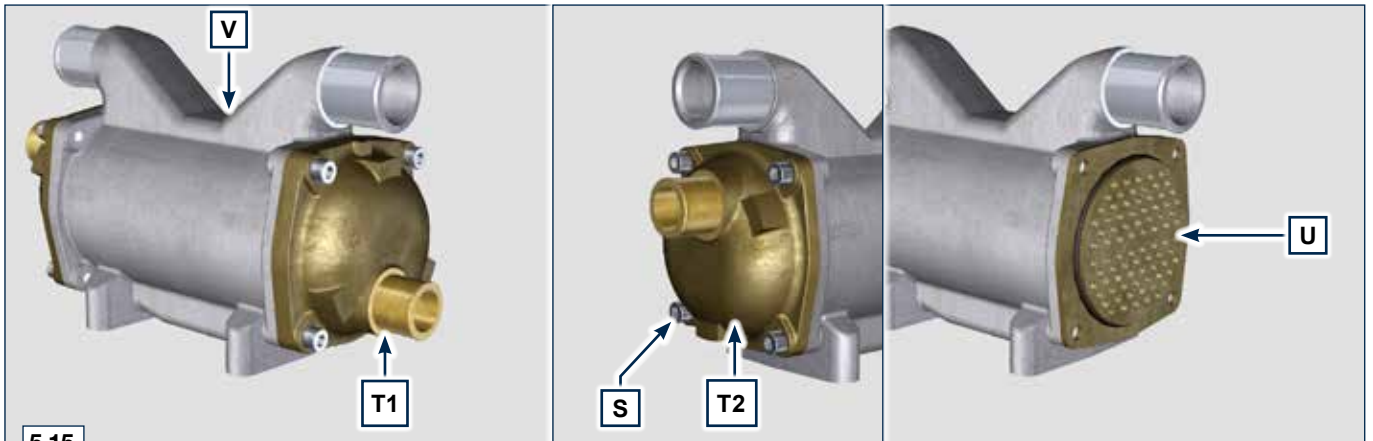
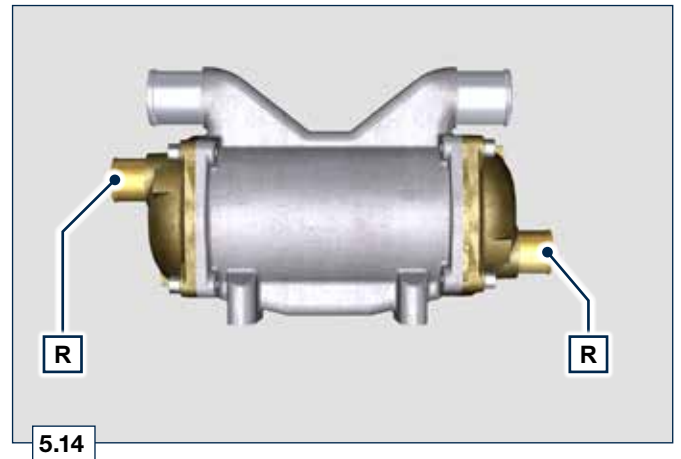

21. Check the intercooler U for any kind of encrustations and dirt, wash with water mixed with alkaline soap suitable for aluminum material.
22. Check all the holes on the surfaces U1, U2 for any kind of encrustations and dirt.

NOTE: *if the inner side of the hoses on the surfaces U1 and U2 are encrusted even after the cleaning carried out in point 17 and 20, clean the hoses with specific mechanical tools.*

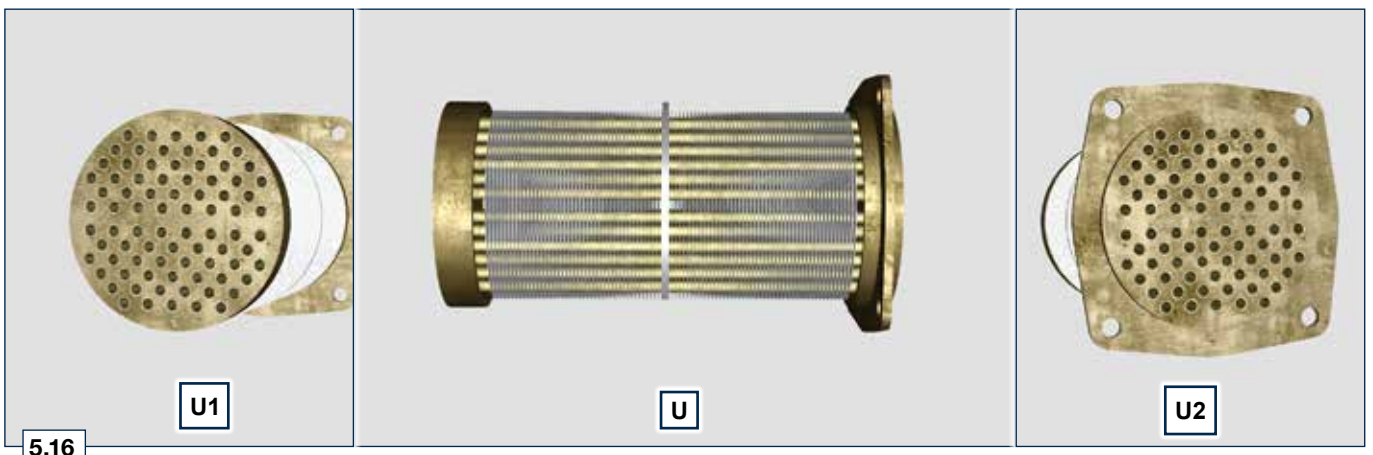

23. Position the gasket Q4 on the intercooler U.
24. Insert the Intercooler U into the support V until it stops.
25. Insert the gasket Q5 on the intercooler U.

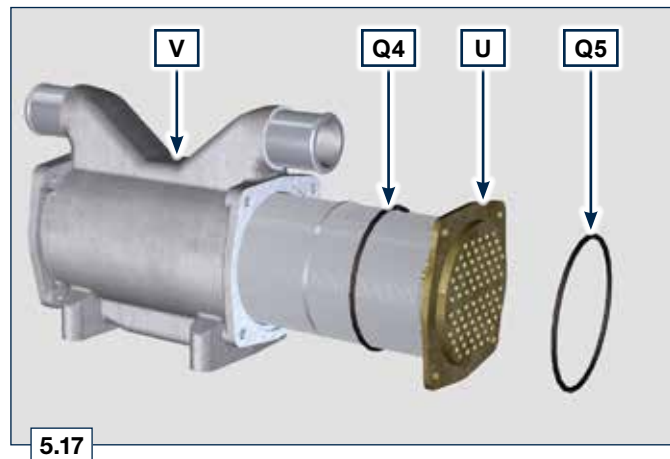

26. Fix the cap T1 on the support V with the screws M (tightening torque of 25 Nm).
27. Insert the gasket Q6 on the intercooler U until it touches the support V and fix the cap T2 on the support V with the screws M (tightening torque of 25 Nm).

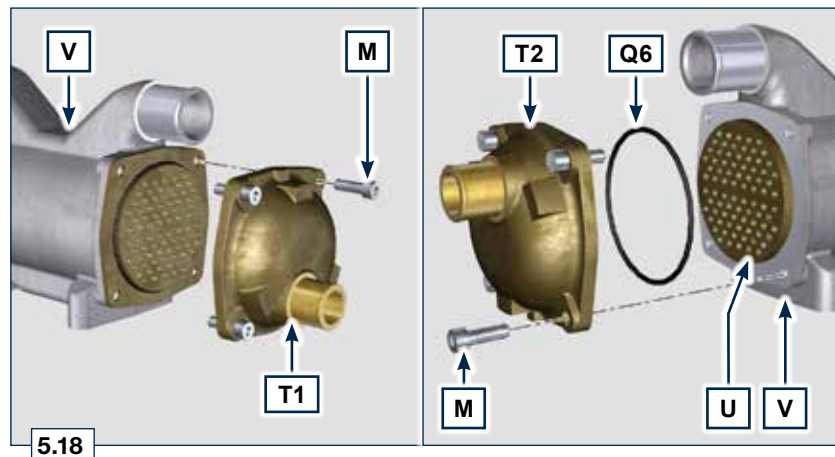

28. Fix the component J to the component K using the screws L and the washers W (tightening torque of 25 Nm).

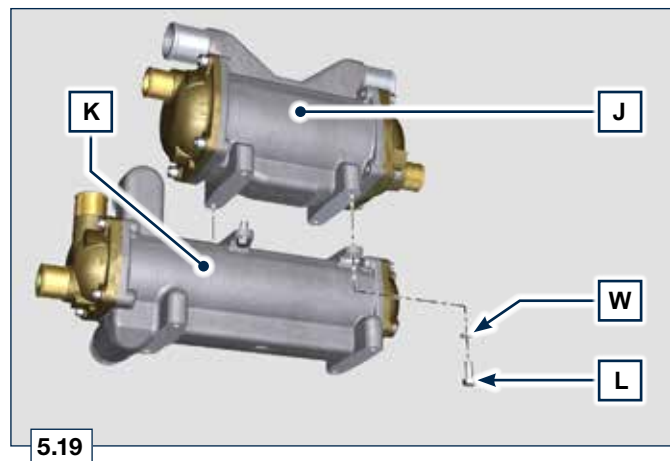

29. Fix the unit J and K on the plate X with the screws H and the washers W.
30. Fit the manifolds F and G on the components J and K, fix all the manifolds with clamps E (Fig. 5.8)
31. Perform the operations described in Par. 6.4.

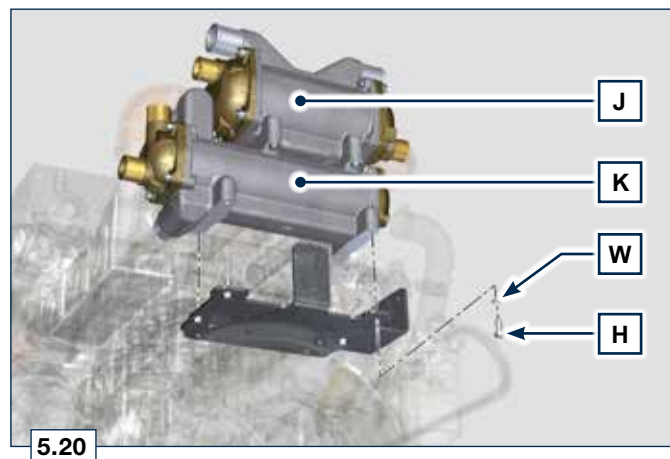

5.7 Check and setting alternator standard belt tension

5.7.1 Check

1. Check the belt A condition, if worn out or deteriorated, replace it.
2. Check by the appropriate tool that at point p the tension value is between 80 and 85 Hz.
3. Using the tool F (DENSO BTG-2 or a similar one) shown in the picture, it is possible to check the corresponding value in Newtons, which should be between 350 and 450 N.
4. Should the correct tool not be available, the belt tension can be checked by applying a force in the direction of arrow G of approx' 10kg on the point p. When correctly tensioned the belt must show a movement of less than 10 mm. If not adjust it.

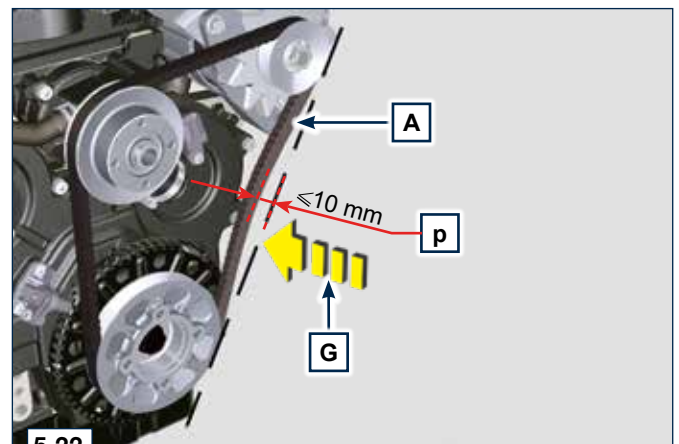
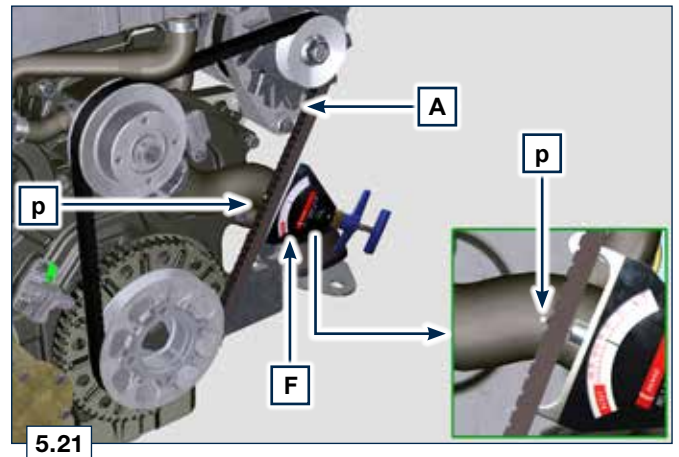

5.7.2 Adjustment

1. Loosen the fastening screws B and C.
2. Pull the alternator outwards (in direction of the arrow D), to tension the belt.
3. Keeping the belt tensed, tighten the screws B and C.
4. Tighten in sequence the screw B (tightening torque of 25 Nm) and C (tightening torque of 40 Nm).
5. Perform the operations described in point 2 of Par. 5.7.1.

NOTE: Contact KOHLER authorised workshops for replacement.

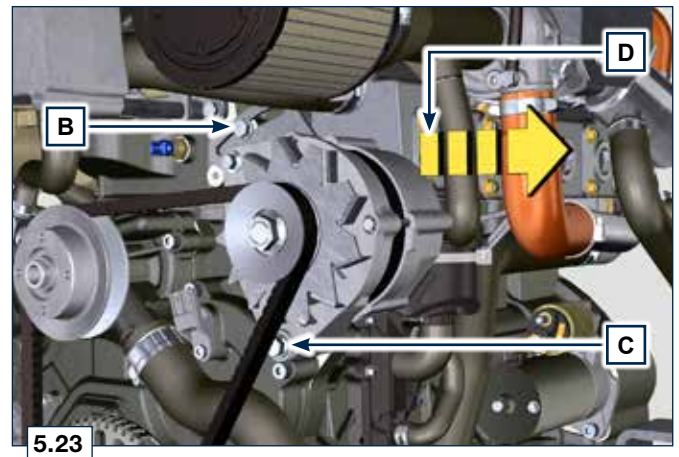

5.8 Control water filter cartridge fuel

NOTE: When turn on lights on control water filter cartridge fuel see [Par. 6.4](#).

1. Gently loosen the wing screw A without removing it.
2. Drain the water if present.
3. Re-tighten the wing screw A as soon as the fuel begins to flow.

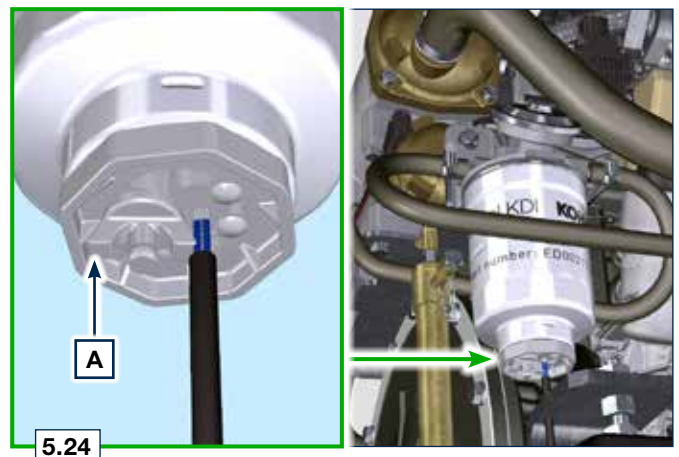

5.9 Product preservation



Important

- If the engines are not to be used for 6 months, they must be protected by carrying out the operations described in Engine storage (up to 6 months) (Par. 5.10).
- If the engine is still not in use after the first 6 months, it is necessary to carry out a further operation to extend the protection period (more than 6 months) (Par. 5.11).
- If the engine is not to be used for an extended period, the protective treatment procedure must be repeated within 24 months of the previous one.

5.10 Engine storage (up to 6 months)

Before storing the engine check that:

- The environments are not humid or exposed to bad weather. Cover the engine with a proper protective sheet against dampness and atmospheric contaminants.
- The place is not near electric panel.
- Avoid storing the engine in direct contact with the ground.

5.11 Engine storage (over 6 months)

Follow the steps described in Par. 5.10.

1. Engine oil replacement ([Par. 6.1](#)).
2. Refuel with fuel additives for long storage.
 - The following additives are recommended:
 - DEFA Fluid Plus (Pakelo Lubricants),
 - Diesel Treatment (Green Star),
 - Top Diesel (Bardhal),
 - STP® Diesel Fuel Injector Treatment.
3. With expansion tank: make sure that the coolant is up to the maximum level.
4. Without expansion tank: Follow the steps described in [Par. 4.6](#).
5. Start the engine and keep it idle at minimum speed for 2 minutes.
6. Bring the engine to 3/4 of the maximum speed for 5÷10 minutes.
7. Turn off the engine.
8. Completely empty the fuel tank.
9. Spray SAE 10W-40 on the exhaust and intake manifolds.
10. Seal the exhaust and intake ducts to prevent foreign bodies from entering.

11. When cleaning the engine, if using a pressure washer or steam cleaning device, avoid directing the nozzle on electrical components, cable connections and sealed rings (oil seals etc).

If cleaning engine with a pressure washer or steam cleaner, it is important to maintain a minimum distance of at least 200mm between the surface to be washed and the nozzle - avoiding absolutely electrical components.

12. Treat non-painted parts with protective products.

If the engine protection is performed according to the suggestions indicated no corrosion damage should occur.

5.12 Engine starting after storage

1. Remove the protective sheet.
2. Use a cloth soaked in degreasing product to remove the protective treatment from the external parts.
3. Inject lubricating oil (no more than 2 cm³) into the intake ducts.
4. Refill the tank with fresh fuel.
5. Make sure that the oil and the coolant are up to the maximum level.
6. Start the engine and keep it idle at minimum speed for a two about minutes.
7. Bring the engine to 75% of maximum rated speed for 5 to 10 minutes.
8. Stop the engine while the oil is still hot ([Par. 6.1](#)), discharge the protective oil in a suitable container.



Warning

- Over time, lubricants and filters lose their properties, so it is important consider whether they need replacing, also based on the criteria described in [Par. 5.2](#).
9. Replace the filters (air, oil, fuel) with original spare parts.
 10. Pour new oil ([Par. 4.5](#)) up to the maximum level.
 11. Empty the cooling circuit completely and pour in the new coolant up to the maximum level ([Par. 6.5](#)).

5.13 Unused machine

If the machine is not used for a certain amount of time, follow the operations below:

5.13.1 Operations for the engine

5.12

POINT	OPERATION	
1	unused machine up to 2 months	<ul style="list-style-type: none"> - The place must be dry and fresh throughout the period in which the machine is not used. - Consult the machine's manual to disconnect the battery (before disconnecting the battery, wait for minimum 5 mins after turning off the engine). - Make sure the engine is not exposed to direct sunlight. - Make sure the engine is not near any heat sources.
	Starting	<ul style="list-style-type: none"> - Before starting the engine, check Par. 5.2 for maintenance operations. - Consult the machine's manual to connect the battery and start the engine.
2	unused machine from 2 to 9 months	<ul style="list-style-type: none"> - Perform the operations related to unused machine described in point 1. - Perform the operations described in Par. 5.6. - Start the engine at least every 4 months as per operations described in point 1: - Avoid sudden accelerations for the first few minutes. Bring the engine to the working temperature by pressing the accelerator 3/4 from MAX. Leave the engine running at minimum speed for a few minutes and turning off the engine.
	Starting	<ul style="list-style-type: none"> - Before starting the engine, check Par. 5.2 for maintenance operations. - Consult the machine's manual to connect the battery and start the engine. - Avoid sudden accelerations for the first few minutes.
3	unused machine over 9 months	<ul style="list-style-type: none"> - Perform the operations related to unused machine described in point 1 and 2.
	Starting	<ul style="list-style-type: none"> - Before starting the engine, check Par. 5.2 for maintenance operations. - Check the quality of coolant from the relative testing strips. - Consult the machine's manual to connect the battery and start the engine. - Avoid sudden accelerations for the first few minutes.

**Danger**

Disconnect the negative wire (-) from the battery to avoid accidental engine starting.

**Important**

Before proceeding with operation, read [Par. 3.2.2](#)

6.1 Engine oil replacement**Important**

- Place engine on horizontal surface to ensure accurate measurement of oil level.
- Before proceeding, perform the operation described in Par. 6.2 - Point 1.

NOTE: *Perform this operation with warm engine, to get a better fluidity of the oil and get a full discharge of oil and impurities contained in it.*

1. Loosen the oil filler cap A.
2. Remove the oil dipstick B (Fig. 6.3).
3. Remove oil drain plug D from pump E.
4. Start pump E and drain the oil in the engine.
5. Drain oil in an appropriate container. (For the exhausted oil disposal, refer to [Par. 6.8 DISPOSAL](#) and [SCRAPPING](#)).
6. Tighten the drain oil plug D (tightening torque at 10 Nm).
7. Perform the operation described in [Par. 6.2](#) - point 2 to 5.
8. Add the type oil recommended ([Tab. 2.1](#) and [Tab. 2.2](#)).
9. If the plug A is not accessible, use the oil filler cap C.
10. Fit and remove the oil dipstick B to check the level. Pour in fluid until reaching the MAX level mark.
11. Upon completion, reinstall the oil dipstick B completely.
12. Tighten the cap A or C.

**Important**

- Do not exceed the MAX level on the dipstick.
- Do not use the engine with the oil level below the MIN.

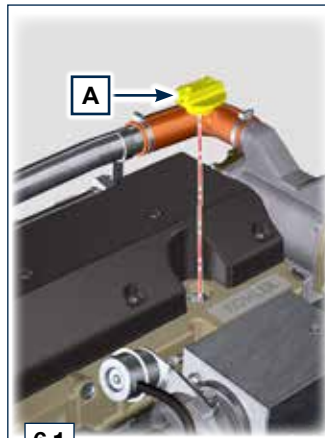

6.1

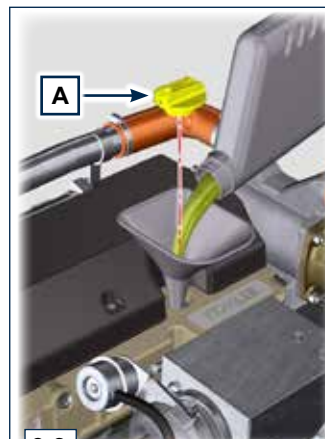
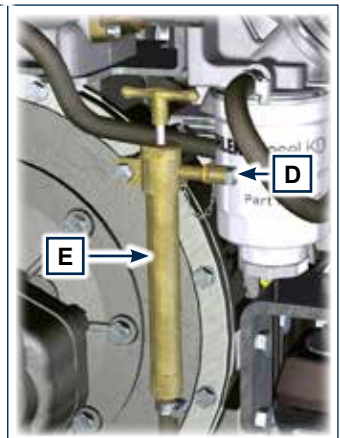

6.2

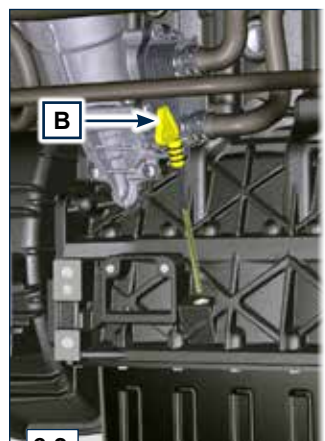
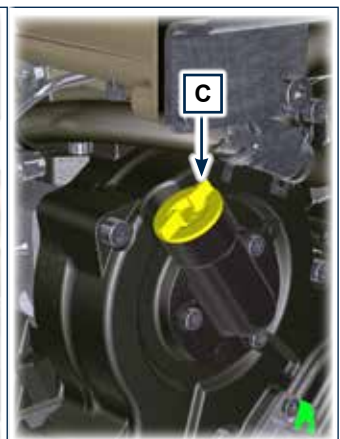

6.3

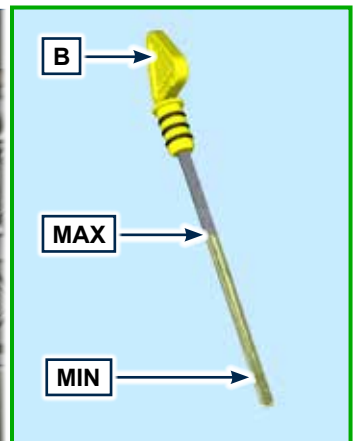



Warning

- **Oil filter cartridge replacement (Par. 6.2) and fuel filter replacement (Par. 6.3)**

In case of low use replace it 12 months.

1. For disposal of oil filter cartridge and fuel filter refer
2. to [Par. 6.8 DISPOSAL and SCRAPPING.](#)

6.2 Oil filter cartridge replacement



Important

- Electric/pneumatic screwdrivers are forbidden.

1. Unscrew cartridge holder cover A by performing three complete turns and wait 1 minute.

NOTE: this operation allows to oil contained in the support F to flow into the oil sump in the correct way.

2. Unscrew cartridge holder cover A and check that the oil in the lub. oil filter support F has flowed towards the oil sump.
3. Remove the cap A as well as the oil cartridge B from the oil filter support.
4. Remove the oil cartridge B and replace it with a new one. Remove and replace the gaskets C.
5. Tighten the cover A on the oil filter bracket F (tightening torque of 25 Nm).

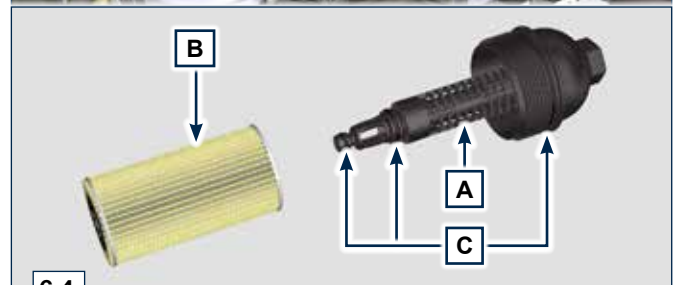

6.4

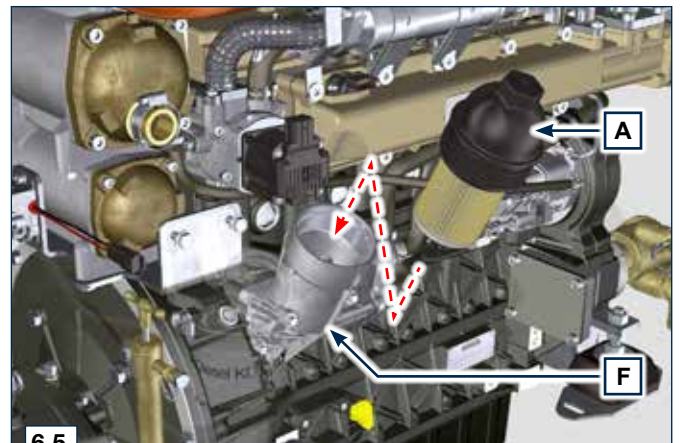

6.5

6.3 Fuel filter cartridge replacement



Important

- Do not fill the new cartridge B with fuel.
- Replace the gaskets D and dampen them with oil.

1. Disconnect the cable A of the water presence sensor C.
2. Remove the water presence sensor C from its cartridge B.
3. Unscrew the cartridge B.
4. Tighten the new cartridge B on the fuel filter bracket E (tightening torque of 17 Nm).
5. Tighten the water presence sensor C on the new cartridge B (tightening torque of 5 Nm).
6. Reconnect the cable A of the water presence sensor C.
7. Push repeatedly the button F in order to fill the circuit.

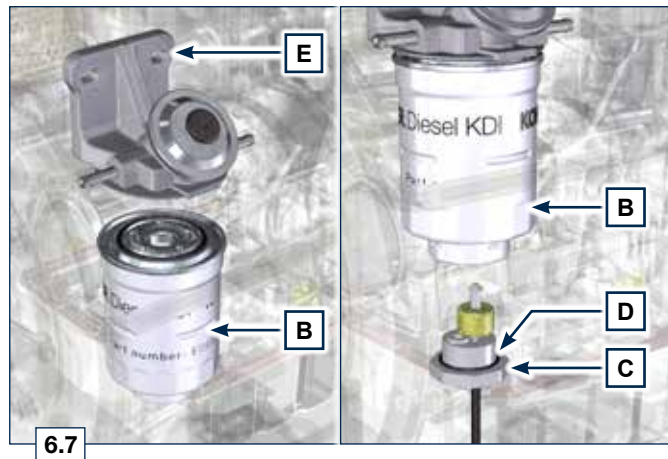
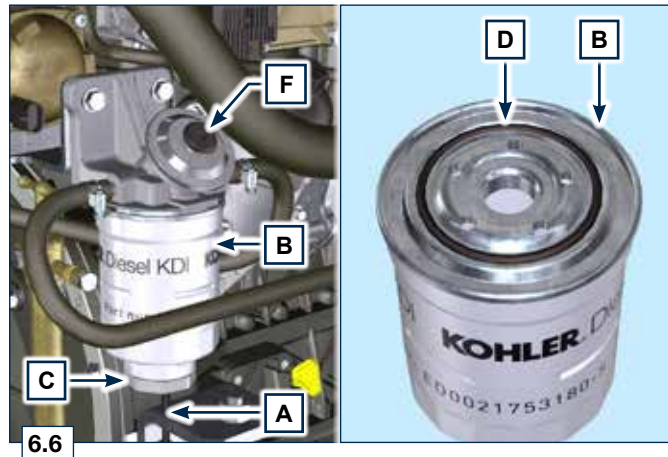

6.4 Water pump impeller replacement



Important

- Replace gasket G.

1. Loosen capscrews A and remove cover B.
2. Remove impeller C from pump body D.
3. Grease the new impeller C.
4. Insert the new impeller C onto shaft E.
5. Fasten cover B with capscrews A (tightening torque of 5 Nm) and insert gasket G between cover B and pump body D.

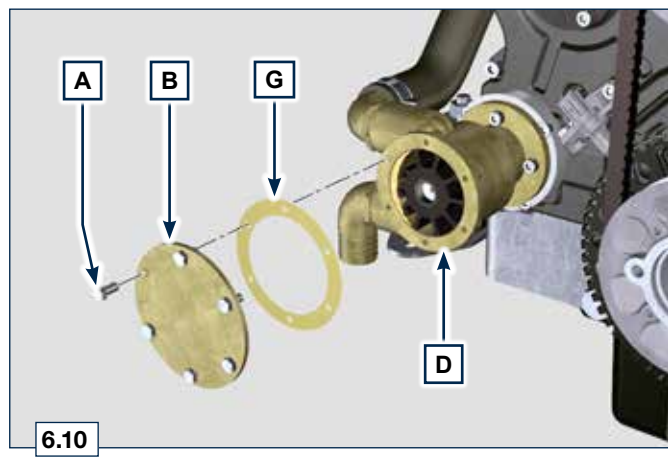
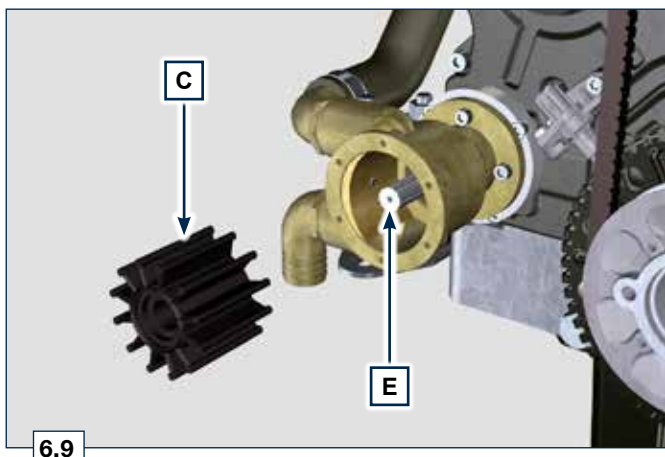
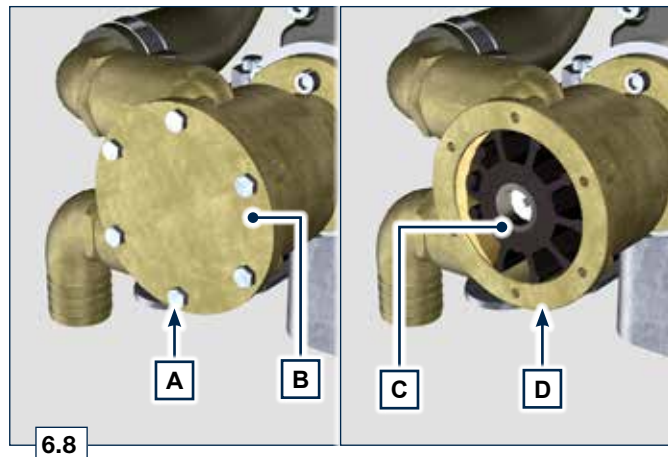

6.5 Alternator belt replacement



Important

• Before proceeding with operation, carefully read [Par. 3.3.2](#).

1. Loosen the screws A and B.
2. Push the alternator C in the direction of the arrow D and remove the belt E.
3. Push the alternator C in the direction of the arrow D.

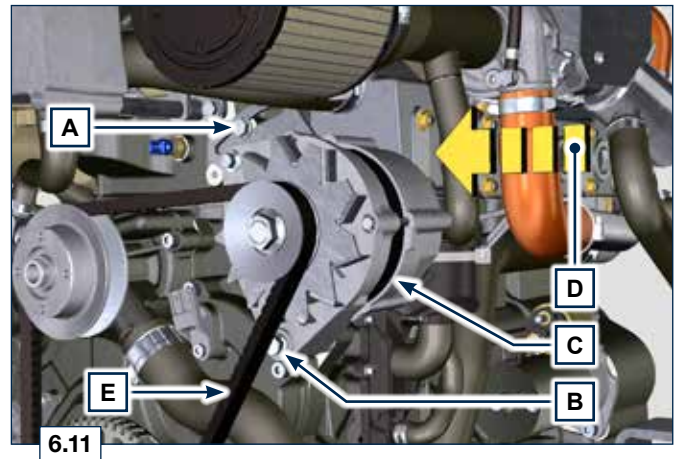

4. Insert the belt E on the pulleys F.

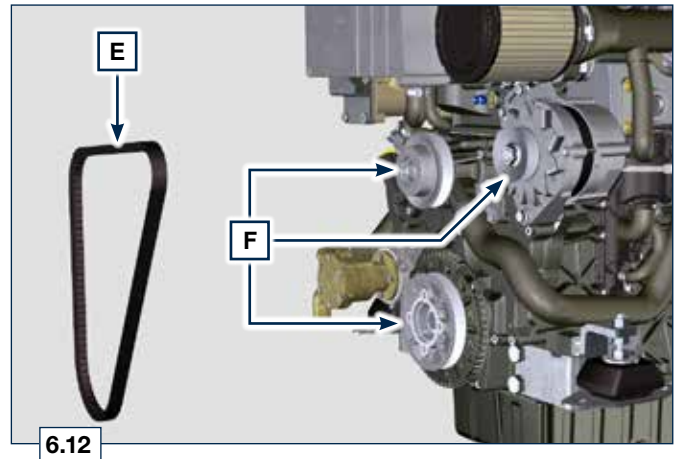

5. Pull the alternator C in the direction of the arrow G.
6. While tensioning the alternator C, first clamp screw A (tightening torque at 25 Nm) and then screw B (tightening torque at 41 Nm).
7. Check the tension of the belt E with the instrument (DENSO BTG-2), positioning it in point P (the tension must be between 350 and 450 N). Should the correct tool not be available, the belt tension can be checked by applying a force in the direction of arrow H of approx' 10kg on the point P. When correctly tensioned the belt must show a movement of less than 10mm. If not adjust it.

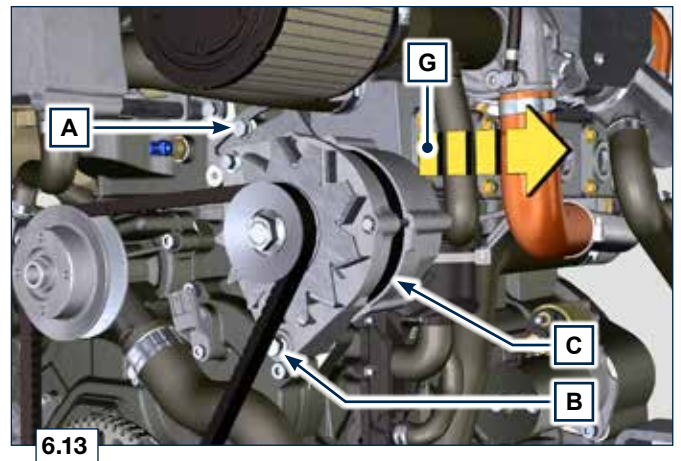

8. If the tension values do not correspond, tighten screws A and B, then repeat operations 6, 7 and 8.

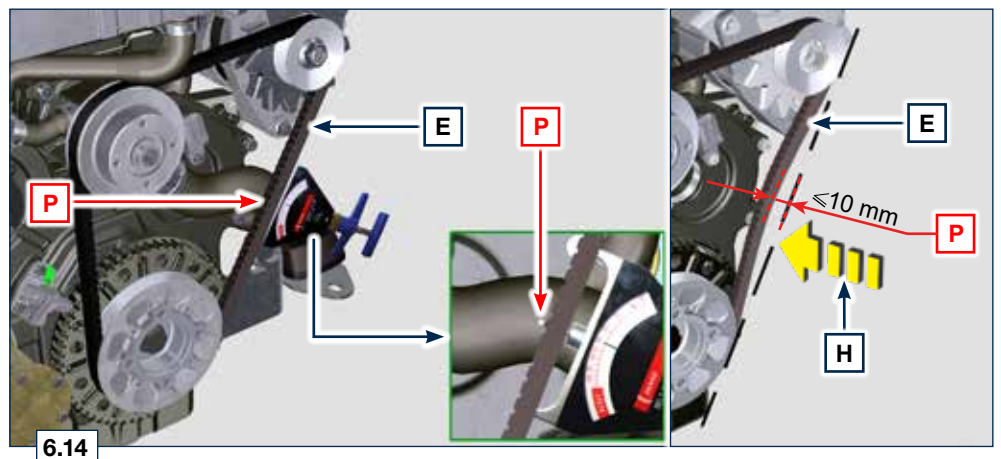

6.6 Coolant replacement

1. Undo cap A to drain all liquid from the system contained in the engine crankcase ducts into an appropriate container (Par. 3.5).



Important

- Perform the operations described in Par. 5.6 before proceeding.
- Replace gasket C.

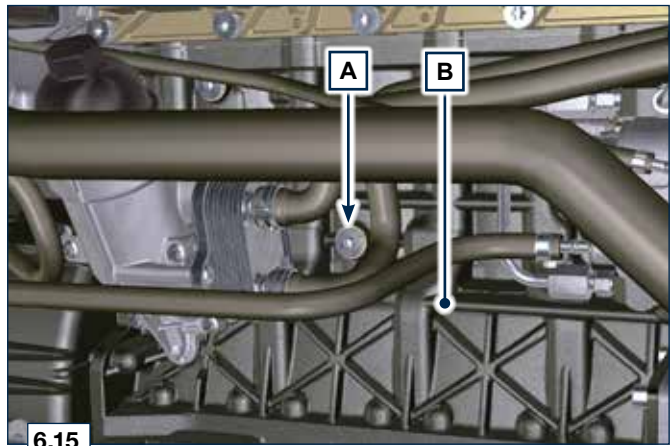

6.15

2. Screw cap A onto crankcase B, inserting gasket C (tightening torque 50 Nm).
3. Perform the operations described in Par. 4.7.

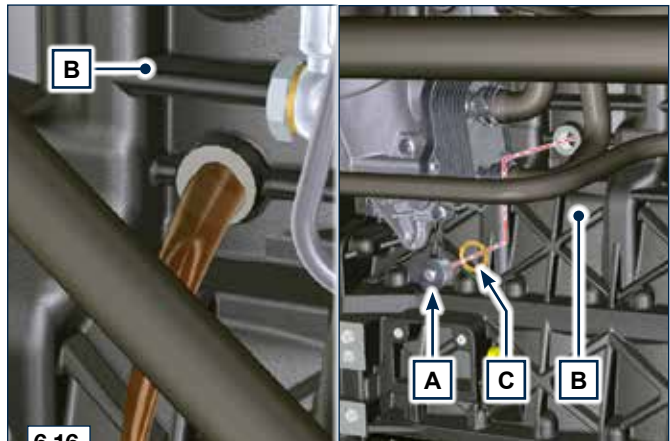

6.16

6.7 Air cleaner replacement

1. Loosen clamp A and remove filter B from support C.
2. Fasten the new air cleaner B onto support C using clamp A.

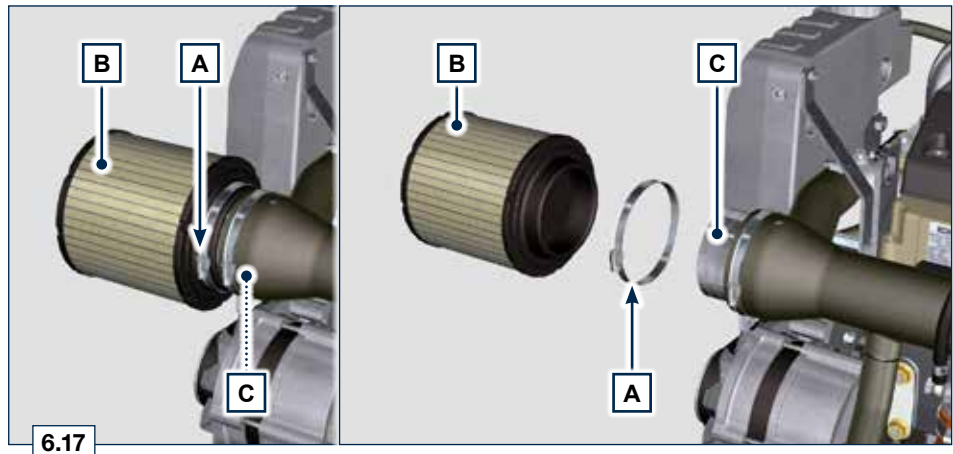

6.17

6.8 Disposal and scrapping

- In case of scrapping, the engine shall be disposed of in appropriate locations, in conformity with the law in force.
- Before scrapping, it is necessary to separate the rubber or plastic parts from the rest of the components.
- The parts only composed of plastic material, aluminium and steel can be recycled if collected by the appropriate centers.
- Waste oil must properly be recycled and disposed of in the correct way to safeguard the environment. According to the laws in force, it is classified as hazardous waste, therefore it must be collected by the appropriate centers.

7.1 Useful information about failures

- This chapter contains information about the problems that may appear during engine operation with its causes and trouble shooting Tab. 7.2.
- In some cases, you shall turn off the engine immediately to avoid further damage Tab. 7.1.

7.13

THE ENGINE MUST BE IMMEDIATELY TURNED OFF WHEN

1	Warning RED light turn on
2	The oil pressure indicator light turns on while running
3	The engine rpms suddenly increase and decrease
4	A sudden and/or unusual noise is heard
5	Colour the exhaust fumes suddenly darkens





7.14

TROUBLES	POSSIBLE CAUSE	SOLUTION	PAR.
Error code	Engine ECU has detect a malfunctions	Contact KOHLER authorised workshops	--
The engine does not start	Sulphated battery terminals corroded	Clean the battery terminals	--
	Battery voltage too low	Recharge the battery or replace it	--
	Low fuel level	Refuel	4.4
	Frozen fuel	Contact KOHLER authorised workshops	--
	Clogged fuel filter	Replace with a new filter	6.4
	Air suction in fuel system	Contact KOHLER authorised workshops	--
	Clogged air filter	Replace with a new filter	6.5
	Clogged pipes	Contact KOHLER authorised workshops	--
	Open fuse	Replace with a new fuse	--
	Intake or exhaust system clogged	Contact KOHLER authorised workshops	--
	Engine starts but stops	Inefficient electrical connections	Clean the electrical contacts
Sulphated battery terminals		Clean the battery terminals	--
Clogged fuel filter		Replace with a new filter and clean the tank	--
Clogged fuel pipes		Contact KOHLER authorised workshops	--
Engine doesn't rev up	Safety protocol in starting	Wait some seconds	--
	Throttle to MAX in starting	Release the throttle and wait some seconds	--
RPM instability at idle speed	Clogged fuel pipes	Contact KOHLER authorised workshops	--
Low idle speed	Clogged fuel pipes	Contact KOHLER authorised workshops	--
	Poor quality fuel	Clean the tank and refuel with quality fuel	2.5
Blue smoke	High oil sump level	Replace the engine oil	--
	Clogged air filter	Replace with a new filter	6.5
Excessive fuel consumption	Clogged air filter	Replace with a new filter	6.5
	High oil sump level	Replace the engine oil	--
Engine lost its initial performance	Clogged air filter	Replace with a new filter	6.4
	Clogged fuel pipes	Contact KOHLER authorised workshops	--
	Cheap fuel	Clean the tank and refuel with quality fuel	--
	High oil sump level	Replace the engine oil	--
Slow acceleration	Clogged fuel filter	Replace the fuel filter	6.4
Engine jerking	Clogged fuel pipes	Contact KOHLER authorised workshops	--
Engine overheats	Insufficient coolant level	Fill up to the level	4.6
	High oil sump level	Replace the engine oil	--
	Clogged radiator	Clean the radiator	--

7.2 Error signals on the control panel

Tab. 7.3 shows the errors that can be generated on the control panel.

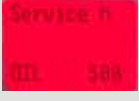
7.15

POS.	DESCRIPTION
	Engine oil pressure low
	High coolant temperature
	Disabled alternator (with engine rpm < 850 rpm)
	Maintenance service (*1)
	Insufficient battery voltage (flashing display with battery < 9 V)
	Fault code

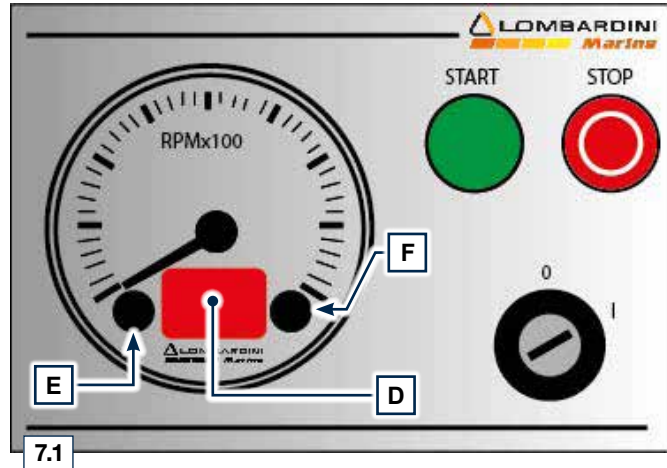

7.1

Besides visual signals, acoustic errors are also transmitted from the panel.

Any errors disappear automatically once the anomaly has been solved.

(*1) - A maintenance service does not automatically carry out a reset; it must be reset manually, as follows:

1. Press the E push button until the maintenance service page (Service h) is displayed on the screen D.
2. Simultaneously press push buttons E and F for 10 secs. for screen D to reset the hours until the next maintenance.

3.1 Application and Validation process for marine engine

Kohler Engines educates his sales and service network in order to carry out the installation and commissioning of the engine with functional checks in respect of the standards established over the years and the requirements set out in the technical documents (owner manuals).

Installation by unauthorized personnel (end customer or other) is allowed by Kohler Engines just in the case that the instructions given on the technical documents accompanying the engine are observed (owner manual, installation manual provided on request); in case of non-observance of the instructions the warranty is to be considered as not applicable.

The warranty is activated from the sales invoice date to the final customer.

Below you can find some examples of the types of application of a marine engine for propulsion:

- a) the classical transmission in line with the shaft connected to the crosshead;
- b) an example of hydraulic transmission;
- c) a s-drive transmission.

Among other differences, note the position of the propeller moved forward and farther than the ship's wheel.

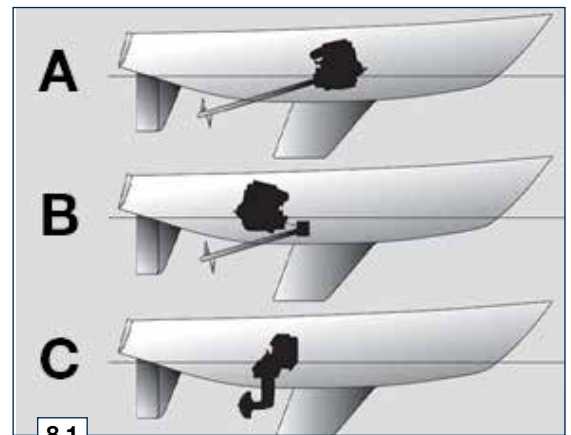

The application process (installation on a boat) of a marine engine for propulsion must be carried out respecting some consolidated norms as per the attached scheme:

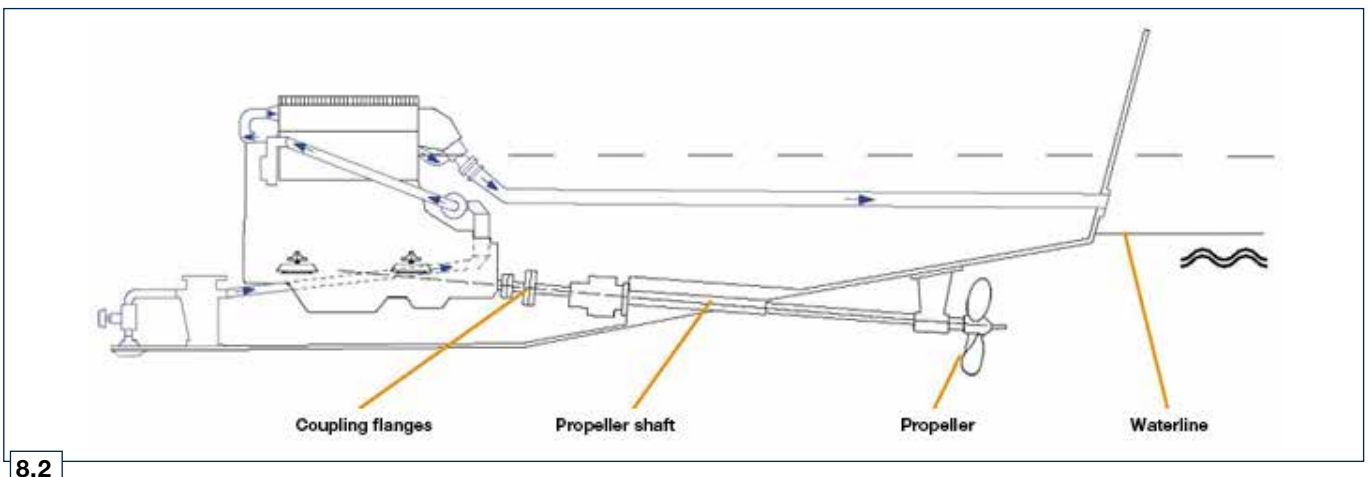

8.2 Prescriptions to be respected

During the installation operations, the following instructions must be observed:

Compliance with the maximum inclinations permitted (owner manual)

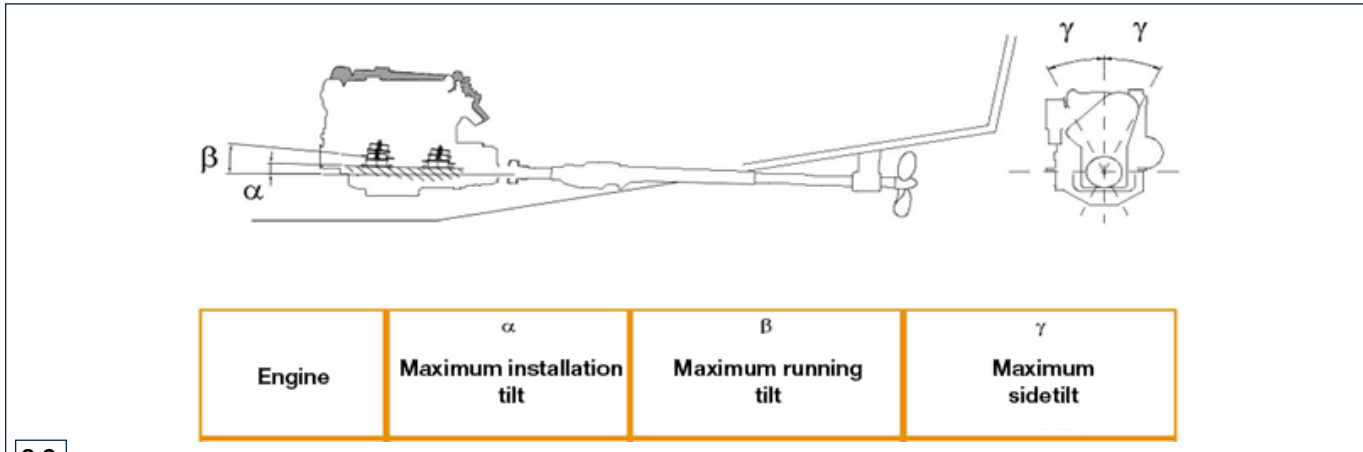

8.3

Engine below sea level with airvent valve installation scheme

If sea water outlet is at height of less than 200 mm from the water line, fit an airvent system.

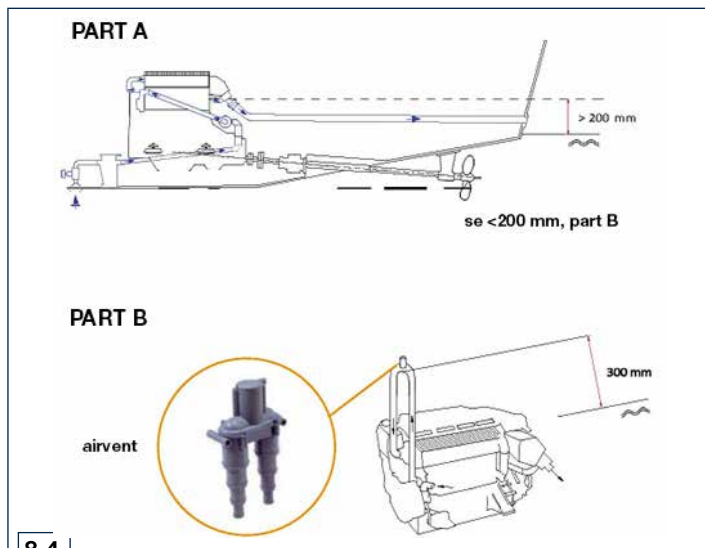

8.4

Exhaust line with muffler and terminal siphon installation scheme

If the exhaust line is ascending and the sea water exit from the engine is under the waterline, install a muffler and a non-return siphon.

Muffler must hold a large volume of water included between the muffler and the exhaust exit.



8.5

Fuel circuit connection scheme

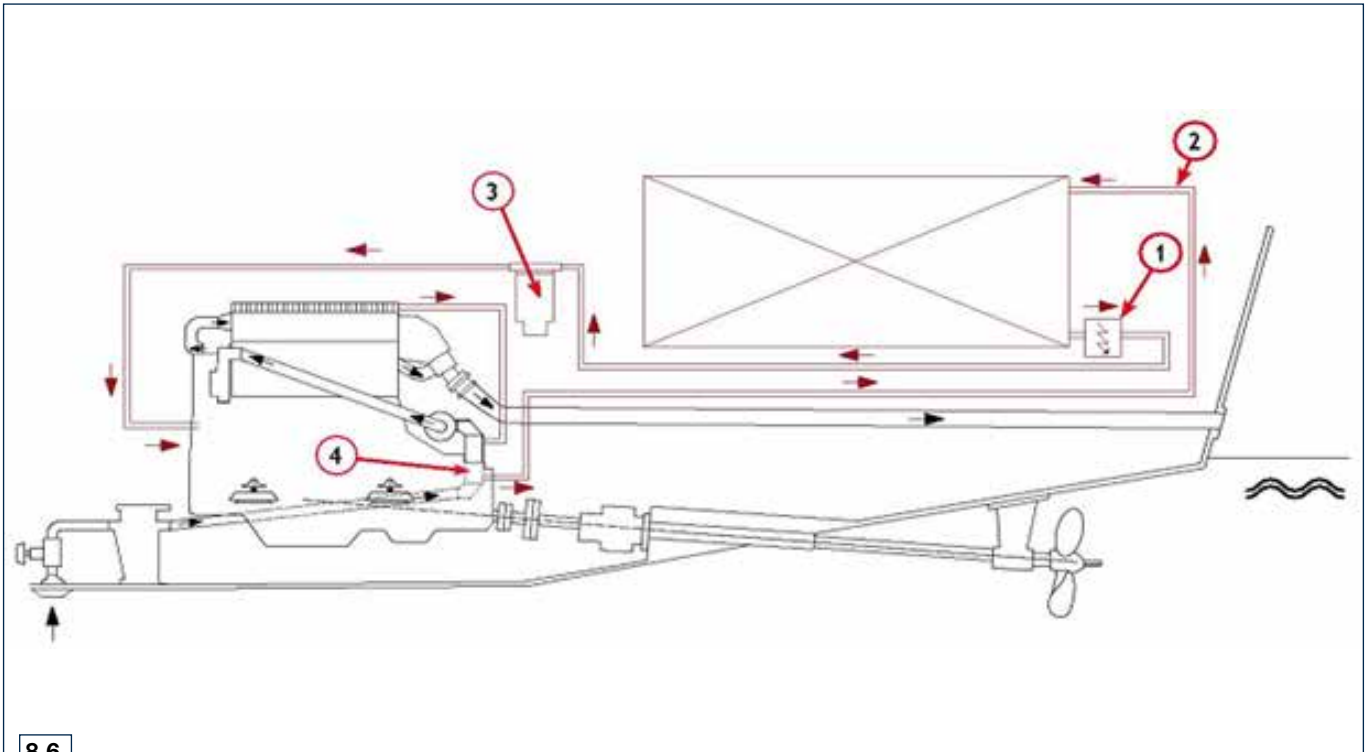

1. Fuel supply shut-off valve on the tank
2. Fuel return shut-off valve on the tank
3. Fuel prefilter with water separator (10 micron)
4. Fuel cooler interposed on fuel return pipe on the tank

Supports anti-vibration position and adjustment scheme

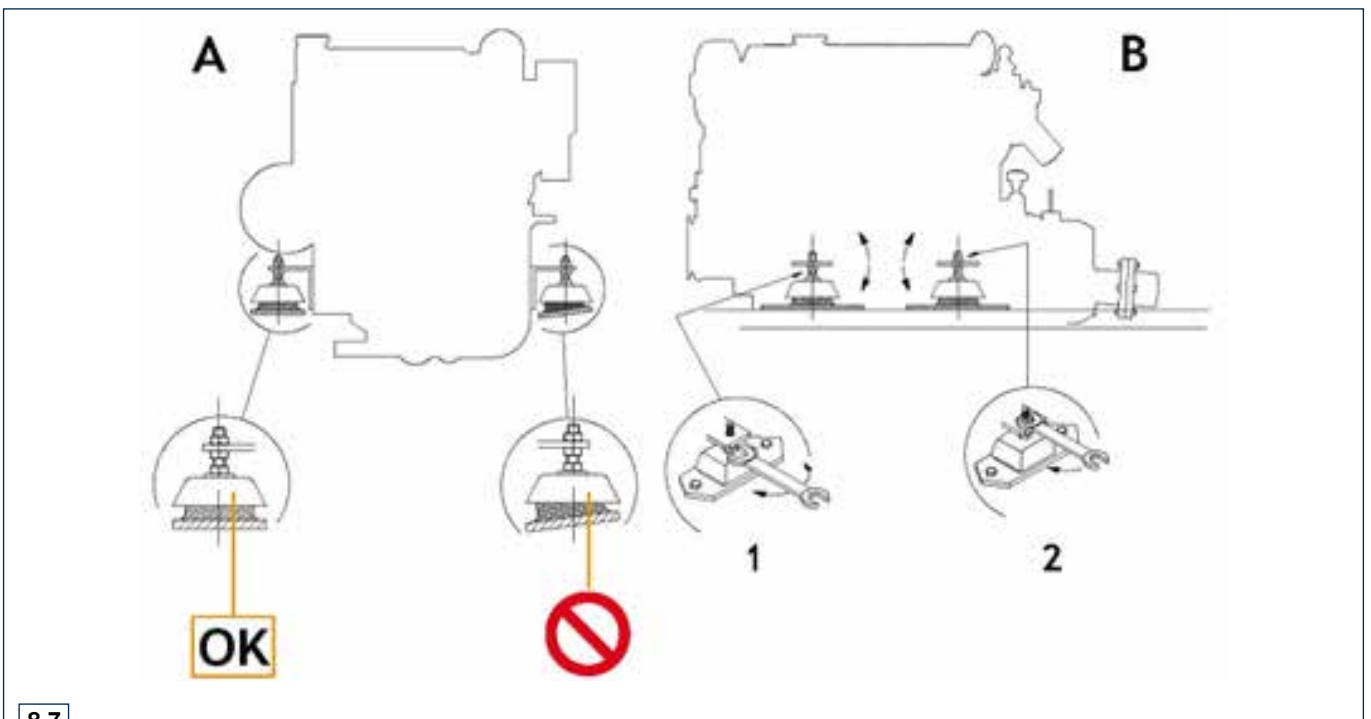

Connection and alignment to the axis line scheme

Accurate alignment is done by adjusting the elastic supports and locking them when the correct position has been found. Engine and inverter must be aligned with the propeller shaft in two ways. The traditional measurement is made using a thickness gauge and the alignment can be considered correct when the measured value is within 0.125 mm.

Angular alignment

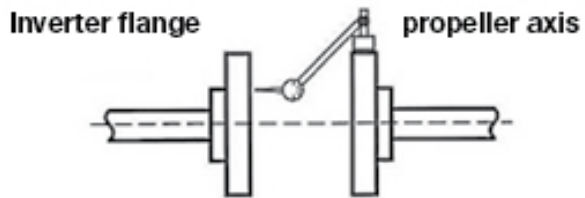

Wrong angular alignment

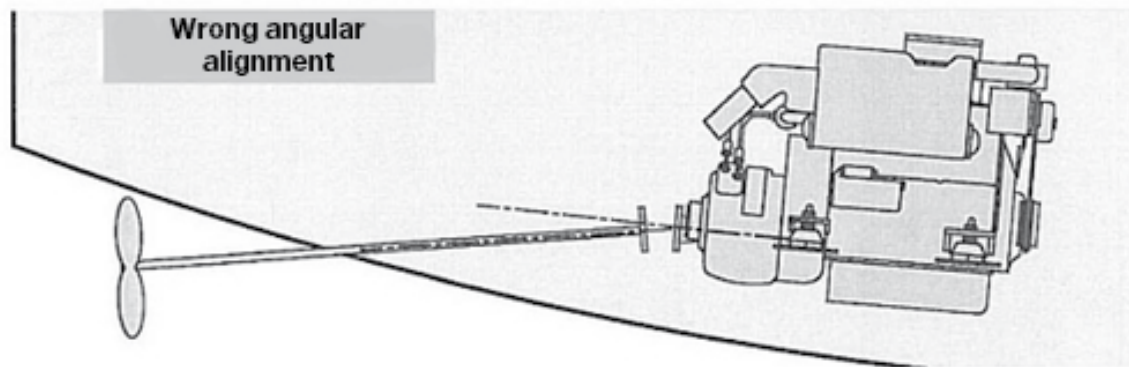
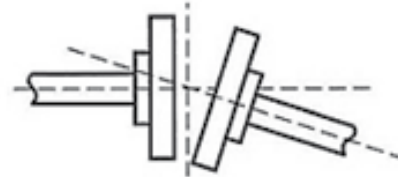

Parallel alignment

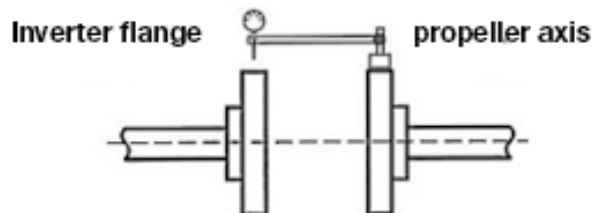

Right parallel alignment

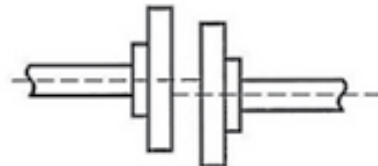

8.8

Extraction and ventilation engine room scheme

Mandatory

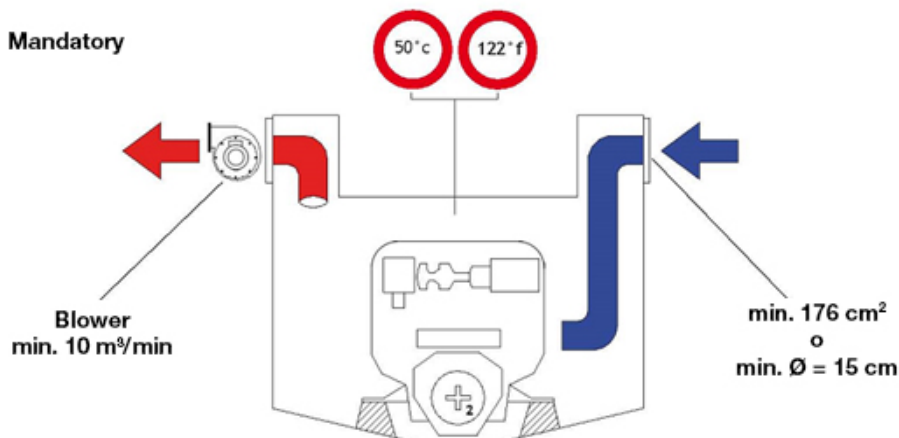

8.9

KOHLER DIESEL ENGINES GLOBAL WARRANTY TERMS
1. WARRANTY PERIOD

Kohler Co. warrants to the End User that each Diesel engine will be free from manufacturing defects in materials or workmanship in normal service for the applicable coverage period or operating hours (whichever comes first) set forth below, provided the engine is operated and maintained in accordance with Kohler Co.'s instructions and manuals.

ENGINE SERIES	WARRANTY PERIOD	OPERATING HOURS	WARRANTY COVERAGE
KOHLER Diesel (non KDI)	3 Years	0 – 2.000	100% Parts & Labor
KOHLER KDI	3 Years	0 – 2.000	100% Parts & Labor
		2.001 – 6.000	Major Components Only*
Lombardini Diesel	2 Years	0 – 2.000	100% Parts & Labor

**Major component defects are failures related to crankcase casting, cylinder head casting, crankshaft, crankshaft pulley, camshaft, connecting rod, flywheel, oil pump.*

For the Warranty Period stated above, the period begins on the date of purchase of the finished equipment on which the engine is installed. If no hour meter is installed on the application, the Operating Hours will be calculated as 4 hours of use per day for 5 days per week beginning on the date of purchase.

Kohler Co.'s obligation under this warranty is expressly limited, at its option, to an appropriate adjustment, repair or replacement of such part or parts as found to be defective following an inspection by Kohler Co. or an authorized service facility designated by Kohler Co.

SPARE PARTS	WARRANTY PERIOD	OPERATING HOURS	WARRANTY COVERAGE
KOHLER and Lombardini Diesel Parts	2 Years	0 – 2.000	100% Parts & Labor

Parts/components that are scheduled to be replaced as part of the required maintenance schedule will be covered under Kohler Co.'s warranty from date of purchase of the part up to the first scheduled replacement point for the subject parts/ components.

All other Spare Parts items are covered by the above warranty provided that the repairs have been executed by Kohler Co or by an Authorized Kohler Service Dealer.

2. EXCLUSIONS

The following items are not covered by this warranty.

- Damage caused by: (i) an accident or casualty; (ii) unreasonable use or neglect; (iii) normal wear; (iv) premature wear from improper maintenance; (v) improper storage; (vi) old or contaminated fuel left within the fuel system, which includes but is not limited to tanks, fuel lines, or fuel injection components; (vii) unapproved modifications.
- Failures caused by: (i) faulty repairs made by any party other than Kohler Co. or an authorized service facility designated by Kohler Co.; (ii) use of non-Kohler replacement service parts; or (iii) additional damages caused by a lack of prescribed actions as a result of an alarm light activation, either caused by fault or negligence or un-attended use of the engine; (iv) an act beyond the control of Kohler Co., which includes but is not limited to theft, vandalism, fire, lightning, earthquake, windstorm, hail, volcanic eruption, flood or tornado.
- Transportation charges or travel expenses in connection with the repair or replacement of defective parts on the engine.
- Engine accessories such as fuel tanks, clutches, transmissions, power drive assemblies, and batteries, unless supplied or installed by Kohler Co.
- Engines installed in an application not formally reviewed by Kohler.
- Rental of other equipment during performance of warranty repairs All items subject to wear and to periodical maintenance such as listed in the Use & Maintenance Manual (such as air, oil or fuel filters, belts etc.) are warranted for a period equal to the prescribed interval of replacement as listed in the Manual.
- Fuel, lubricating oil, coolant/antifreeze.

IMPLIED OR STATUTORY WARRANTIES, INCLUDING THOSE OF MERCHANTABILITY AND FITNESS FOR A PARTICULAR PURPOSE, ARE EXPRESSLY LIMITED TO THE DURATION OF THIS WRITTEN WARRANTY. KOHLER CO. MAKES NO OTHER EXPRESS WARRANTY, NOR IS ANYONE AUTHORIZED TO MAKE ANY ON KOHLER CO.'S BEHALF. KOHLER CO. AND/OR THE SELLER SHALL NOT BE LIABLE FOR SPECIAL, INDIRECT, INCIDENTAL, OR CONSEQUENTIAL DAMAGES OF ANY KIND.

3. TO OBTAIN WARRANTY SERVICE

The repair shall be executed by a KOHLER Authorized Service Dealer designated by Kohler.

USA & CANADA:

List of Authorized dealers can be found by visiting www.kohlerengines.com or telephone 1-800-544-2444 (U.S.A. and Canada) ENGINE DIVISION, Kohler Co., Kohler Wisconsin

EUROPE, MIDDLE EAST, AND ASIA

List of Authorized dealers can be found by visiting dealers.kohlerpower.it.

CENTRAL AND SOUTH AMERICA:

List of Authorized dealers can be found by visiting dealers.kohlerpower.it.

CHINA AND ASIA PACIFIC

List of Authorized dealers can be found by visiting dealers.kohlerpower.it.

INDIA

List of Authorized dealers can be found by visiting dealers.kohlerpower.it.

Note: Specific Warranty Terms and conditions do apply to engines directly sold in India.

4. OWNER'S WARRANTY RESPONSIBILITIES

1. As the off-road engine owner, you are responsible for the performance of the required maintenance listed in your Use & Maintenance Manual. Kohler Co. recommends that you retain all receipts covering maintenance on your off-road & marine engine, but Kohler Co. cannot deny warranty solely for the lack of receipts or for your failure to ensure the performance of all scheduled maintenance.
2. As the off-road & marine engine owner, you should however be aware that Kohler Co. may deny you warranty coverage if your off-road & marine engine or a part shows signs of malfunction or failed due to abuse, neglect, improper maintenance or unapproved modifications.
3. Your engine is designed to operate on diesel fuel only. Diesel fuel and all other fluids used shall comply with the recommendation listed in the Use & Maintenance Manual. Use of any other fuel or fluids may result in your engine breakage, premature wear or no longer operating in compliance with the California & US EPA emissions requirements.
4. You are responsible for initiating the warranty process. The ARB & US EPA suggests that you present your off-road & Marine engine to a Kohler Co. dealer as soon as a problem exists. The warranty repairs should be completed by the dealer as expeditiously as possible.

5. COVERAGE

Kohler Co. will repair or replace emission control system parts, components and sub-assemblies found to be defective with respect to materials or workmanship at no cost to you including engine exhaust system related diagnosis, labor and parts, provided that no un-authorized modification of any kind has been executed on the engine, and its parts, components and sub-assemblies.

The choice and responsibility of the decision to repair or replace an emission control system defect will be solely that of Kohler Co. Emission control system parts/ components covered by the Federal and California Emission Control Systems Limited Warranty are listed below

engine is defective, the part will be repaired or replaced by Kohler Co.

Fuel injector(s)	Electronic control unit (ECU) if equipped
Injection pump(s)	Sensors associated with ECU operation
Exhaust manifold	Emission control information labels
Intake manifold	Turbocharger (if equipped)
Exhaust gas recirculation (EGR) tube	Fuel limiting device
Crankcase ventilation valve	Aftertreatment Systems if equipped and other components when present

Parts/components that are scheduled to be replaced as part of the required maintenance schedule will be covered under the warranty provisions for a period of time up to the first scheduled replacement point for the subject parts/ components. Subsequent damage to other engine components as a direct result of a warrantable failure an exhaust emission part/ component will be covered under the warranty provisions described herein.

6. MAINTENANCE AND REPAIR REQUIREMENTS

The owner is responsible for the proper use and maintenance of the engine. Kohler Co. recommends that all receipts and records covering the performance of regular maintenance be retained in case questions arise. If the engine is resold during the warranty period, the maintenance records should be transferred to each subsequent owner. Kohler Co. may not deny warranty repairs solely because of the lack of repair, maintenance or failure to keep maintenance records.

Normal maintenance, replacement or repair of emission control devices and systems may be performed by any repair establishment or individual; however, warranty repairs must be performed by a Kohler authorized service center.

7. CALIFORNIA AND FEDERAL EMISSION CONTROL WARRANTY STATEMENT, OFF-ROAD & MARINE DIESEL ENGINES (USA ONLY)

The California Air Resources Board (CARB), U.S. environmental protection agency (EPA), and Kohler Co. are pleased to explain the emission control system warranty on your [current model year – {2+ current model year}] off-road compression ignition and marine (diesel) engine. In California (“the state”) and US EPA regulated region, new heavy-duty off-road & marine engines must be designed, built and equipped to meet the state’s and US EPA anti-smog standards. The warranty period shall begin on the date the engine or equipment is delivered to an ultimate purchaser. Kohler Co. must warrant the emission control system on your engine for the periods of time listed in the section below, provided there has been no abuse, neglect or improper maintenance of your engine.

Your emission control system may include parts such as the fuel injection system and the air-induction system. Also included maybe hoses, belts, connectors and other emission related assemblies.

When a warrantable condition exists, Kohler Co. will repair your heavy-duty off-road & marine engine at no cost to you including diagnosis, parts and labor.

The owner shall not be charged for diagnostic labor that leads to the determination that a warranted part is in fact defective, provided that such diagnostic work is performed at a warranty station.

MANUFACTURER’S WARRANTY COVERAGE:

The [current model year – {2+ current model year}] heavy-duty off-road & marine engines are warranted for the periods listed below. If any emission-related part on your engine is defective, the part will be repaired or replaced by Kohler Co.

VARIABLE SPEED OR CONSTANT SPEED	KW <19	ANY SPEED	1,500 HOURS OR TWO YEARS, WHICHEVER COMES FIRST.
Constant speed	19 ≤kW <37	3,000 rpm or higher	1,500 hours or two years, whichever comes first.
Constant speed	19 ≤kW <37	Less than 3,000 rpm	3,000 hours or five years, whichever comes first.
Variable speed	19 ≤kW <37	Any speed	3,000 hours or five years, whichever comes first.
Variable speed or constant speed	kW ≥37	Any speed	3,000 hours or five years, whichever comes first.

MARINE DIESEL ENGINE

ENGINE POWER	WARRANTY PERIOD
kW < 19	1,500 hours or 2,5 years, whichever comes first.
19 ≤ kW < 37	2,500 hours or 3,5 years, whichever comes first.
37 ≤ kW < 75	5,000 hours or 5 years, whichever comes first.

A	Alternator:	A component that transforms mechanical energy into AC electrical energy.
	Authorised workshop:	Kohler authorised service centre.
B	Bore:	Internal diameter of the cylinder in combustion engines.
C	Catalyst:	A device in charge of filtering exhausted gas.
	Combustion:	Chemical reaction of a mixture composed of fuel and fuel (air) inside a combustion chamber.
	Common Rail:	A high-pressure "Common Duct" that produces a constant supply of fuel directly to the injectors.
E	EC:	European Community.
	ECU:	Electronic Control Unit; an electronic device in charge of electronically detecting and controlling other electronic control devices.
	EGR Cooler:	Recirculated exhaust gas cooling; a system that is able to cool recirculated gas (EGR) from the exhaust. This enables the temperature to remain constant inside the intake manifold, thus improving combustion inside the cylinders and breaking down pollutants further.
	EGR:	Exhaust Gas Recirculation, in internal combustion engines; a system that enables recirculation of combusted gas by means of taking it in once again, which enables it to break down a part of the pollutants present in the exhaust gas.
	Electronic injector:	An electronically activated component able to inject jets of atomised fuel inside the cylinders.
	EPA:	Environmental Protection Agency. The United States' authority that safeguards the environment; its duty is to govern and control polluting emissions.
F	Fig.:	Figure.
G	Galvanised:	Material that has undergone surface protection treatment.
H	Heavy conditions:	Type of extreme condition referred to the work environment in which the engine is used (very dusty - dirty area, or in a contaminated environment due to various types of gas).
I	Intercooler:	Air-cooling element under pressure from the turbo situated between the turbine and intake manifold.
K	KDI:	Kohler Direct Injection
M	Maintenance - periodic:	A group of maintenance actions that have the sole objective to control and replace elements on their expiry, without modifying or improving the functions carried out by the system, neither increasing the value nor improving performance.
	MAX:	Maximum.
	Methyl ester	It is a mixture of products by means of a chemical conversion of oils and animal and/or vegetable fat, which is used to produce Biofuel.
	MIL:	Malfunction Indicator Lamp
	Min.:	Minutes.
	MIN:	Minimum.
	Model:	Model, engine identification plate, which indicates the engine's model.
O	Oil Cooler:	Small radiator used to cool the oil.
P	Par.:	Paragraph.
	Paraffin:	Fatty and solid substance that may form inside the diesel.
	PWM:	Pulse Width Modulation" is a digital signal sent from the EGR valve to the EGR-ECU, which interprets the position of the valve.
R	Ref.:	Reference.

S	s/n:	Serial number (engine identification name plate) indicating the engine identification series/chassis number.
	Sec.:	seconds
	Spec.:	Specification, (engine identification name plate) indicating the engine version.
T	Tab.:	Table.
	Tightening torque:	A term indicated for installation of threaded components and which is determined by means of a unit of measurement Nm.
	T-MAP:	T-MAP (sensor), measures the temperature and absolute pressure inside the intake collector.
	Turbocharger:	Device that compresses air intake by sending it to the intake manifold by means of a turbine.
U	Used oil:	Oil altered by operation or time, which is no longer compliant for correct lubrication of the components.
W	Waste-Gate valve:	A device, which is directly or automatically controlled, used to limit the pressure of exhaust gas inside the turbine.
Z	Zinc anode:	Element whose purpose is to prevent the corrosion of components due to the water flow from the water pump

SYMBOLS AND UNITS OF MEASUREMENT

SYMBOL	UNIT OF MEASUREMENT	DESCRIPTION	EXAMPLE
α	degree	Rotation/inclination angle	1°
cm ²	square centimetre	Area	1 cm ²
Ø	millimetre	Diameter	Ø 1 mm
Nm	newton-metre	Torque	1 Nm
mm	millimetre	Length	1 mm
µm	1/1000 of a millimetre (micron)		1 µm
h	hour	Time	1 h
g/kWh	grammes per kilowatt per hour	Specific consumption	1 g/kWh
kg/h	kilogramme per hour	Weight/Time	1 kg/h
Lt./min.	litres per minute	Flow rate	1 Lt./min.
Lt./h	litres per hour		1 Lt./h
ppm	parts per million	Percentage	1 ppm
N	newton	Force	1 N
A	Ampere	Intensity of electrical current	1 A
gr.	gramme	Weight	1 gr.
kg	kilogramme		1 kg
W	Watt	Power	1 W
kW	kiloWatt		1 kW
pa	pascal	Pressure	1 pa
KPa	Kilopascal		1 KPa
bar	barometric pressure		1 bar
mbar (1/1000 bar)	barometric pressure		1 mbar
R	Resistance	Resistance to electrical current (referred to a component)	1 Ω
Ω	ohm	Resistance of electrical current	1 Ω
Rpm	revs per minute	Rotation of an axis	1 Rpm
Ra	average roughness expressed in microns	Roughness	Ra = 1
°C	degree centigrade	Temperature	1°C
°F	grado Fahrenheit		1 °F
V	Volt	Electrical voltage	1 V
●	millimetre	Hex-head capscrew	● 1 mm
cm ³	cubic centimetre	Volume	1 cm ³
Lt.	litre		1 Lt.

Area with horizontal dotted lines for writing notes.

A series of horizontal dotted lines for writing notes.

Area with horizontal dotted lines for writing notes.

A series of horizontal dotted lines for writing notes.

Area with horizontal dotted lines for taking notes.

**CALIFORNIA
PROPOSITION 65 WARNING**

Diesel engine exhaust and some of its constituents are known to the State of California to cause cancer, birth defects, and other reproductive harm.



Kohler Engines is a division of Lombardini s.r.l., part of Kohler Group.

Lombardini has manufacturing facilities in Italy, Slovakia and India and sales subsidiaries in France, Germany, UK, Spain and Singapore.

Kohler/Lombardini reserves the right to make modifications without prior notice.

www.lombardinimarine.com

SALES OFFICE

Kohler Engines

Via Cav. del lavoro A. Lombardini n° 2

42124 Reggio Emilia, Italia

T. +39 0522 389311

F. +39 0522 389298

e-mail: sales@lombardinimarine.com